

THERMAL MASS FLOWMETER

iSOLV

INNOVATIVE SOLUTIONS



analytical

bulk flow

distance

FLOW

level

pressure

temperature

industrial
communication

FLOTECH

PROCESS CONTROL & INSTRUMENTATION

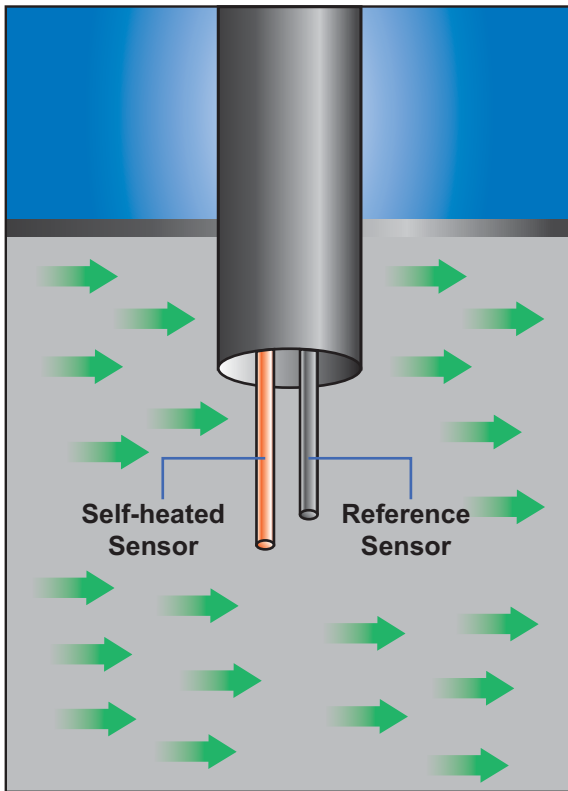

iSOLV THERMAL MASS FLOWMETER

Measuring Principle

iSOLV Thermal Mass Flow Meters have two sensors constructed of reference grade platinum windings (RTDs). The two RTDs are clad in a protective 316SS sheath and are driven by a proprietary sensor drive circuit. One sensor is self-heated and the other sensor measures gas temperature. The pair is referred to as the sensing element, and is either installed in a probe as an Insertion style, or inserted into a pipe section as an In-Line style flow meter.

As gas flows by the flow sensor, the gas molecules carry heat away from the surface, and the sensor cools down as it loses energy. The sensor drive circuit replenishes the lost energy by heating the flow sensor until it reaches the desired temperature difference above the reference sensor.

The electrical power required to maintain a constant temperature differential is proportional to the gas mass flow rate and is linearized to be the output signal of the meter.

iSOLV's proprietary sensor drive circuit maintains the constant temperature difference over the entire operating temperature range of the instrument. The circuit responds quickly to changes in process flow rate or gas temperature.

iSOLV Thermal Mass Flow Meters provide an extremely repeatable (0.2% of Full Scale) and accurate output directly proportional to the mass flow rate of the gas being measured.

Advantages

- Dirt Insensitive
- No Moving Parts
- Ease of Installation
- Negligible pressure drop
- Wide turndown capability of 100 to 1
- Economical solution for large diameters
- Output both flow rate and temperature simultaneously
- Accurate measurement and operation at very low gas pressures and flow rates
- Measures mass flow directly - without additional pressure and temperature inputs

Applications

iSOLV unique thermal mass flowmeter provides exceptionally accurate, highly reliable and repeatable indications of flow rate and operating temperature for air and gas – argon, biogas, methane, chlorine, carbon monoxide, carbon dioxide, digester gas, flare gas, flue gas, hydrogen, helium, landfill gas, nitrogen, natural gas, ammonia gas, oxygen, ozone, propane, mixture gas and many other gases.

iSOLV thermal mass flowmeter has many applications across many industries:

- Water and Waste Water
- Compressed Air
- Natural Gas (Fuel Gases)
- Metals/ Furnaces/ Smelters
- Building Automation
- Landfill
- Glass and Fiberglass
- Food and Beverage
- Pulp and Paper
- Pharmaceutical and Biotech
- Oil & Gas
- Power
- Others

Specification

iSOLV Thermal Mass Flowmeter 30 Series

Type	In-line Integral	Insertion Integral	In-line Remote	Insertion Remote
Model	FGL30	FGI30	FRL30	FRI30
Sensor	Two reference grade platinum RTD clad in 316SS sheath			
Wetted Part	SS316			
Power	24VDC / 115VAC / 230VAC changeable			
Power Dissipation	<2.5 W			
Electronics	Microprocessor based		Remote-style Microprocessor based	
Electronics Enclosure	Integral mount, NEMA 4 enclosure		N/A	
Flow Body / Probe Enclosure	N/A		Junction Box is indoor/outdoor enclosure (no electronics)	
Transmitter Enclosure	N/A		Remote mount. NEMA 4 enclosure	
Display	High contrast photo-emissive OLED graphical display (Flow rate, Totalizer, Temperature)			
Turn Down	100 to 1			
Resolution	1000 to 1			
Low End Sensitivity	5 SFPM			
Field Calibration Check	Yes - Digital system allows raw signal validation (milli-watts)			
Communications	Not Available			
Approvals	Not Available			
Field Configurable	Please contact Flotech			
Flow Accuracy	+/- 0.5% of Full Scale +/- 1% of reading			
Flow Repeatability	0.20%			
Respond Time	1 second			
Gas Temperature Range	-40°C to 90°C Standard (for higher temperature options, contact Flotech)			
Gas Pressure	500 PSIG (if higher pressure needed, contact Flotech)			
Flow Output	4 to 20 mA for Rate; 24VDC pulse for Totalized value			
Temperature Output	Not Available			
Ambient Temperature	-20°C to 65°C			
Flow Body	SS316 Schedule 40 Flow Bodies sized from 1/4" x 6" long to 4" x 12" long. Male NPT ends standard (Flanges and other options available)	N/A	SS316 Schedule 40 Flow Bodies sized from 1/4" x 6" long to 4" x 12" long. Male NPT ends standard (Flanges and other options available)	N/A
Probe Style / Length	N/A	1/2" OD Probe (3/4" optional) Lengths 6" to 36"	N/A	1/2" OD Probe (3/4" optional) Lengths 6" to 36"
Relays	N/A			
Cable Length	N/A		7.5 m Standard (max. length 300 m)	
Flow Conditioning	Flow Conditioners are built in to In-Line Style Flow Bodies from 1/2" to 4"	Captive Flow Conditioners available upon request with meter purchase	Flow Conditioners are built in to In-Line Style Flow Bodies from 1/2" to 4"	Captive Flow Conditioners available upon request with meter purchase

Dimension (In Inches)

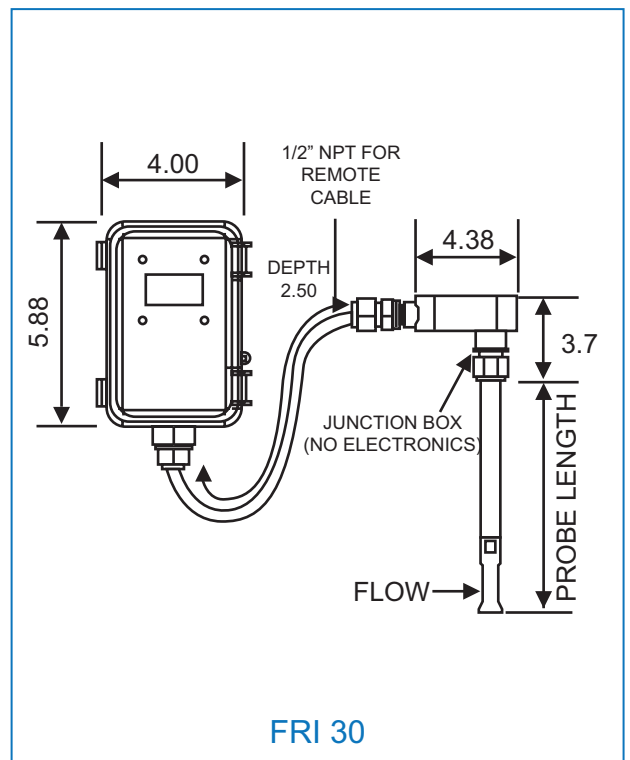
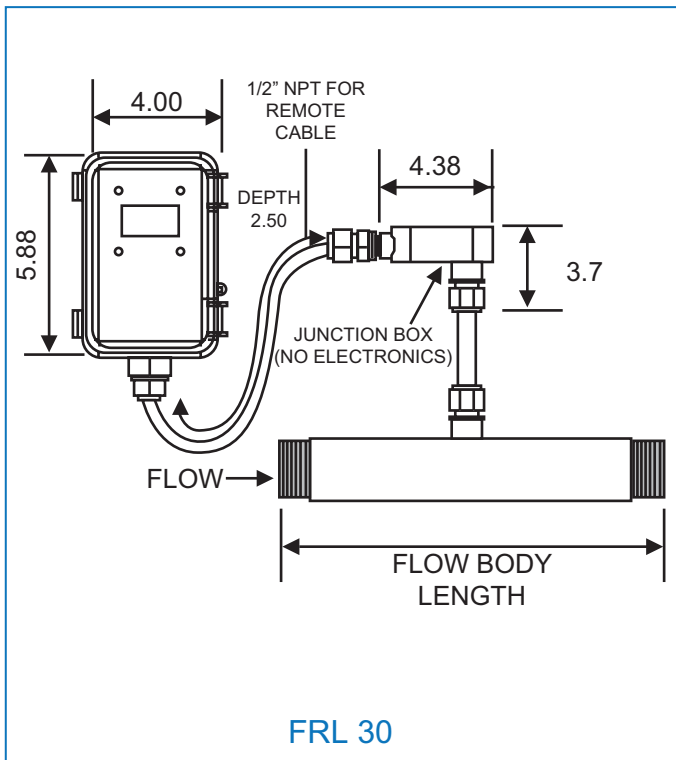
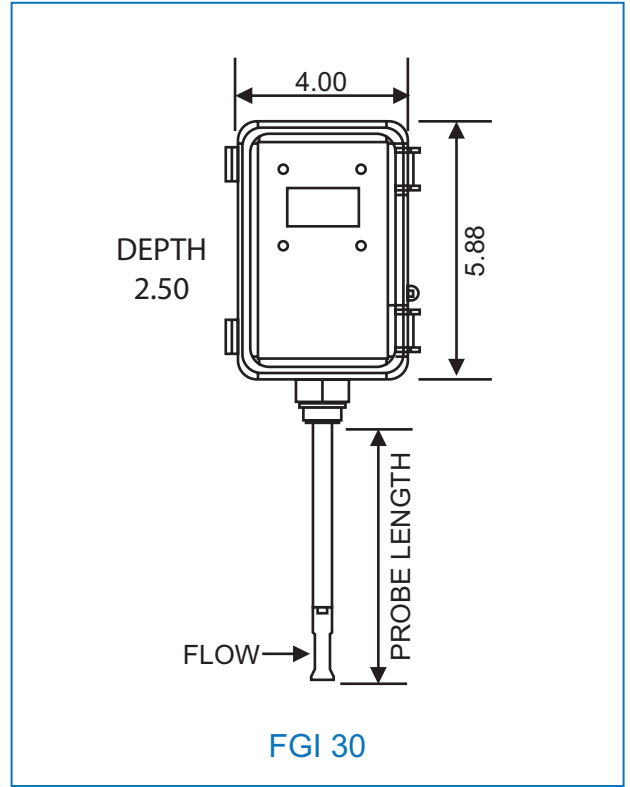
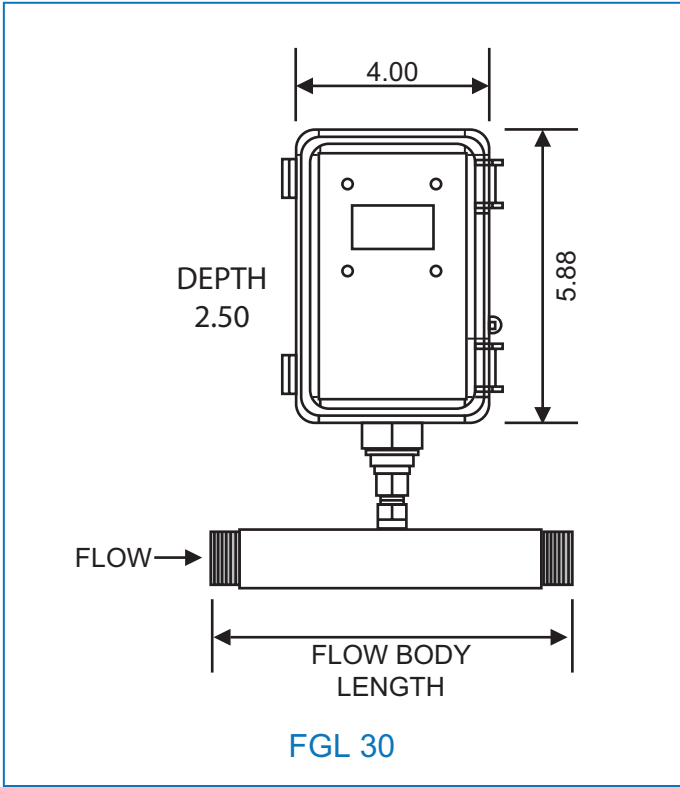

Specification

iSOLV Thermal Mass Flowmeter 90 Series

Type	In-line Integral	Insertion Integral	In-line Remote	Insertion Remote
Model	FGL90	FGI90	FRL90	FRI90
Sensor	Two reference grade platinum RTD clad in 316SS sheath			
Wetted Part	SS316			
Power	24VDC (115 / 230VAC optional)			
Power Dissipation	<2.5 W (for 24 VDC models)			
Electronics	Microprocessor based		Remote-style Microprocessor based	
Electronics Enclosure	Integral Mount, Zone 1, Group IIB+H2, IP66, Class III, Type 4X - Class 1, Zone 1, Groups IIB+H2, IP66		N/A	
Flow Body / Probe Enclosure	N/A		Class 1, Div. 1 & 2, Group B, C, D, Zone 1	
Transmitter Enclosure	N/A		Remote Mount, Zone 1, Group IIB+H2, IP66	
Display	High contrast photo-emissive OLED graphical display (Flow rate, Totalizer, Temperature)			
Turn Down	100 to 1			
Resolution	1000 to 1			
Low End Sensitivity	5 SFPM			
Field Calibration Check	Yes - Digital system allows raw signal validation (milli-watts)			
Communications	Modbus® compliant RS485 RTU communications (HART optional)			
Approvals	Not Available (for hazardous area certification requirements, contact Flotech)			
Field Configurable	Please contact Flotech			
Flow Accuracy	+/- 0.5% of Full Scale +/- 1% of reading			
Flow Repeatability	0.20%			
Respond Time	1 second			
Gas Temperature Range	-40°C to 90°C Standard (for higher temperature options, contact Flotech)			
Gas Pressure	500 PSIG (if higher pressure needed, contact Flotech)			
Flow Output	4 to 20 mA for Rate; 24VDC pulse for Totalized value			
Temperature Output	On display / output with Modbus®			
Ambient Temperature	-20°C to 50°C			
Flow Body	SS316 Schedule 40 Flow Bodies sized from 1/4" x 6" long to 4" x 12" long. Male NPT ends standard (Flanges and other options available)	N/A	SS316 Schedule 40 Flow Bodies sized from 1/4" x 6" long to 4" x 12" long. Male NPT ends standard (Flanges and other options available)	N/A
Probe Style / Length	N/A	1/2" OD Probe, Lengths 6" to 36"	N/A	1/2" OD Probe, Lengths 6" to 36"
Relays	N/A			
Cable Length	N/A		7.5 m Standard (max. length 300 m)	
Flow Conditioning	Flow Conditioners are built in to In-Line Style Flow Bodies from 1/2" to 4"	Captive Flow Conditioners available upon request with meter purchase	Flow Conditioners are built in to In-Line Style Flow Bodies from 1/2" to 4"	Captive Flow Conditioners available upon request with meter purchase

Dimension (In Inches)

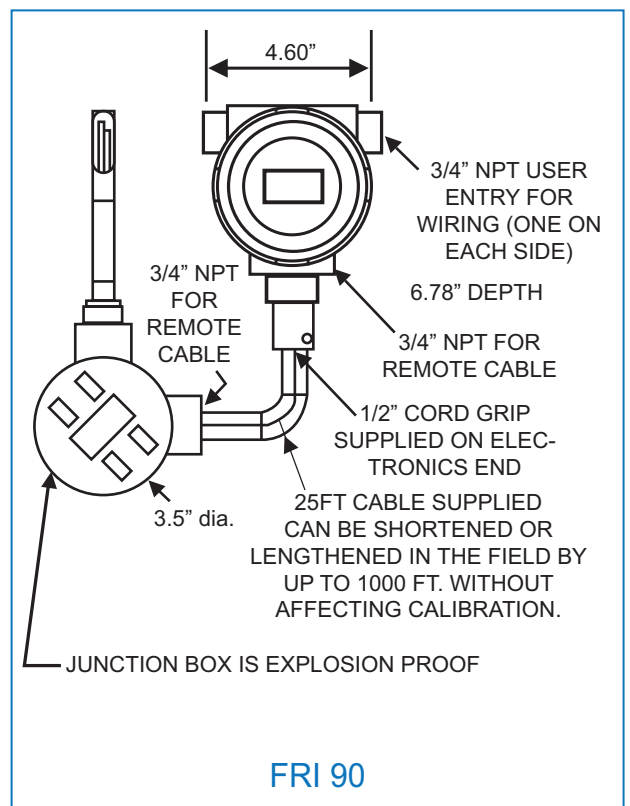
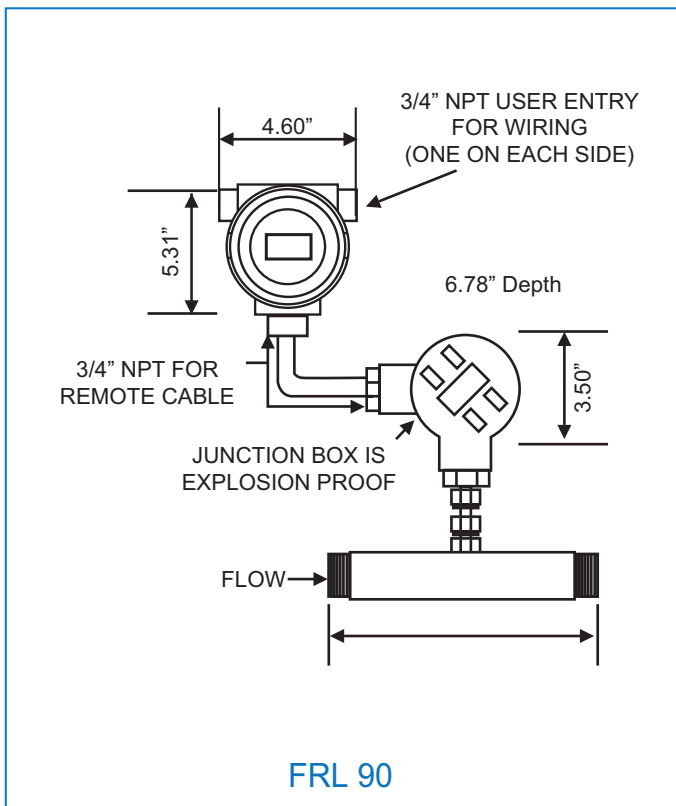
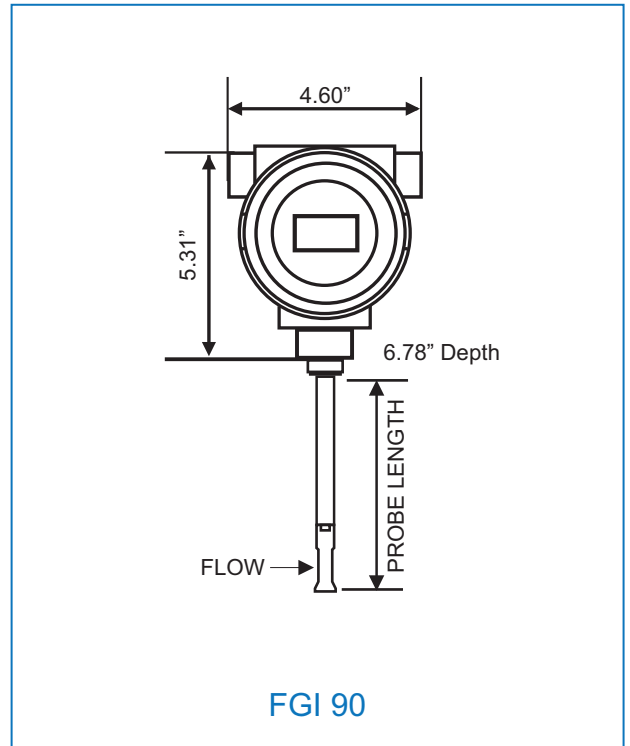
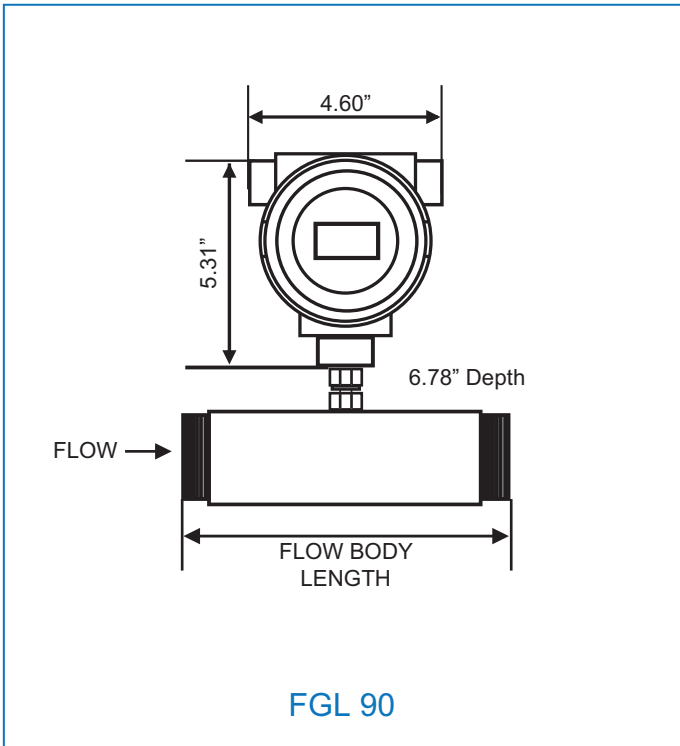

Installation Guide

Choose the longest straight-run section of pipe available to allow a uniform, well-developed flow profile. Allow for a minimum fifteen times diameters of straight run upstream of the sensors even longer for PVC and HDPE pipes and five times diameters straight-run downstream of the sensors. Avoid, if possible, installations immediately downstream of bends, fans, nozzles, heaters and especially valves, or anything else installed in the line that may cause non-uniform flow profiles and swirls. Otherwise signal output errors could result, unless significantly more straight run is provided, or in the absence of sufficient straight run, Flow Conditioners are installed.

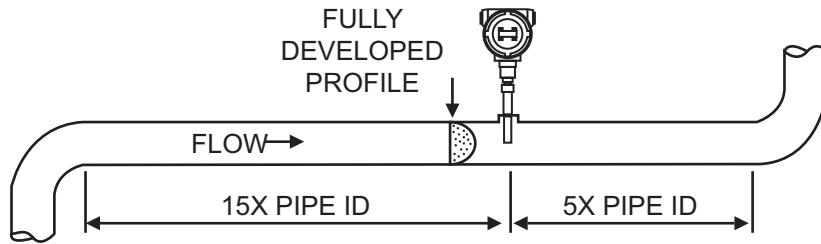

Methods for Probe Insertion to Pipe Center

METHOD 1

Using charts below, select pipe size and determine X. Insert probe until the end touches the bottom of the pipe ID, mark probe as it exits top of fitting. Lift probe distance "X" and tighten compression fitting

METHOD 2

Using charts below, select pipe size and determine Y. Subtract Y from the factory supplied probe length. That difference should be outside of the pipe, and is measured from the bottom of the enclosure of the probe weld to pipe OD.

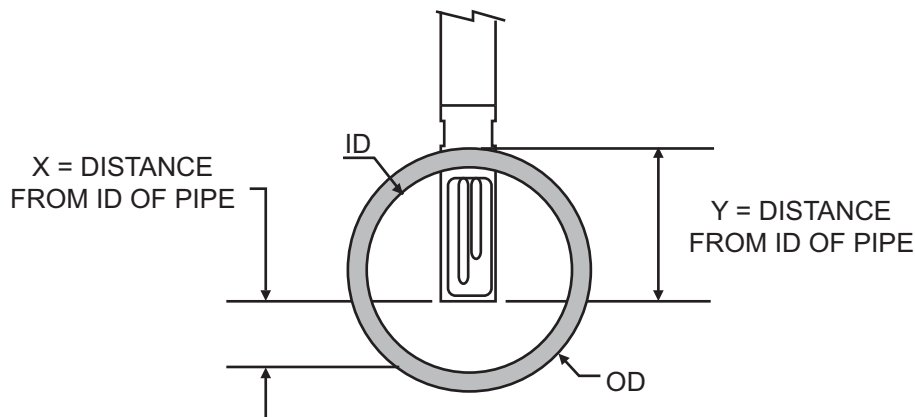

Schedule 40 Pipe					
Pipe Size	OD	ID	X	Y	Pipe Area
1"			Consult Flotech		
1.5"			Consult Flotech		
2"	2.375	2.067	.40"	1.82"	0.0233
2.5"	2.875	2.469	.60"	2.07"	0.0332
3"	3.500	3.068	.90"	2.38"	0.0513
4"	4.500	4.026	1.40"	2.86"	0.0884
6"	6.625	6.065	2.40"	3.95"	0.2006
8"	8.625	7.981	3.40"	4.90"	0.3474
10"	10.750	10.020	4.40"	6.00"	0.5476
12"	12.750	11.938	5.50"	7.00"	0.7773
14"	14.000	13.124	6.00"	7.50"	0.9394
16"	16.000	15.000	7.00"	8.60"	1.2272
18"	18.000	16.876	8.00"	9.60"	1.5533
24"	24.000	22.625	10.75"	12.60"	2.7919

Schedule 80 Pipe					
Pipe Size	OD	ID	X	Y	Pipe Area
1"			Consult Flotech		
1.5"			Consult Flotech		
2"	2.375	1.939	.35"	1.82"	0.0205
2.5"	2.875	2.323	.55"	2.07"	0.0294
3"	3.500	2.900	.80"	2.38"	0.0459
4"	4.500	3.826	1.30"	2.86"	0.0798
6"	6.625	5.761	2.25"	3.95"	0.1810
8"	8.625	7.625	3.25"	4.90"	0.3171
10"	10.750	9.750	4.25"	6.00"	0.5185
12"	12.750	11.374	5.13"	7.00"	0.7056
14"	14.000	12.500	5.70"	7.50"	0.8522
16"	16.000	14.312	6.60"	8.60"	1.1172
18"	18.000	16.124	7.50"	9.60"	1.4180
24"	24.000	21.562	10.25"	12.60"	2.5357

Ordering Information

iSOLV Insertion Style Thermal Mass Flowmeter

(Example)	FGI 30	<p>Model</p> <p>FGI 30 - Insertion Integral</p> <p>FRI 30 - Insertion Remote</p> <p>FGI 90 - Insertion Integral</p> <p>FRI 90 - Insertion Remote</p>
	05	<p>Insertion Style Probe Diameter</p> <p>05 - 1/2" Probe Diameter</p> <p>07 - 3/4" Probe Diameter (Only Available for 30 Series, recommended for 36" probe length)</p>
	06	<p>Insertion Style Probe Length</p> <p>06 - 6" Insertion Probe Length</p> <p>12 - 12" Insertion Probe Length</p> <p>15 - 15" Insertion Probe Length</p> <p>18 - 18" Insertion Probe Length</p> <p>24 - 24" Insertion Probe Length</p> <p>30 - 30" Insertion Probe Length</p> <p>36 - 36" Insertion Probe Length</p>
	F110P	<p>Insertion Style Flanged Probes</p> <p>0 - Without Flange</p> <p>F110P - 150lb ANSI Raised-Face SS Flange for Insertion Meter, 1"</p> <p>F115P - 150lb ANSI Raised-Face SS Flange for Insertion Meter, 1.5"</p> <p>F120P - 150lb ANSI Raised-Face SS Flange for Insertion Meter, 2"</p> <p>F310P - 300lb ANSI Raised-Face SS Flange for Insertion Meter, 1"</p> <p>F315P - 300lb ANSI Raised-Face SS Flange for Insertion Meter, 1.5"</p> <p>F320P - 300lb ANSI Raised-Face SS Flange for Insertion Meter, 2"</p> <p>F330P - 300lb ANSI Raised-Face SS Flange for Insertion Meter, 3"</p> <p>F610P - 600lb ANSI Raised-Face SS Flange for Insertion Meter, 1"</p> <p>F620P - 600lb ANSI Raised-Face SS Flange for Insertion Meter, 2"</p>
	AC115	<p>Power</p> <p>AC115 - 115VAC Operating Power (field switchable to 230VAC)</p> <p>AC230 - 230VAC Operating Power (field switchable to 115VAC)</p> <p>DC24 - 24 VDC Operating Power (Customer Supplied)</p>
	AIR	<p>Gas</p> <p>AIR - Air Calibration</p> <p>AR - Argon Calibration</p> <p>BIOGAS - Biogas (Specify Mix)</p> <p>BUTANE - Butane Calibration</p> <p>CH4 - Methane Calibration</p> <p>CL2 - Chlorine Calibration</p> <p>CO - Carbon Monoxide Calibration</p> <p>CO2 - Carbon Dioxide Calibration</p> <p>DIGGAS - Digester Gas (Specify Mix)</p> <p>ETHYLENE - Ethylene Gas Calibration</p> <p>FLAREGAS - Flare Gas (Specify Mix)</p> <p>FLUEGAS - Flue Gas (Specify Mix)</p> <p>H2 - Hydrogen Calibration</p> <p>H2S - H2S Gas (Dry) Calibration</p> <p>HE - Helium Calibration</p> <p>LFG - Landfill Gas Calibration (Specify Mix)</p> <p>MIX - Mixture Calibration (Specify Mix)</p> <p>N2 - Nitrogen Calibration</p> <p>NG - Natural Gas Calibration</p> <p>NH3 - Ammonia Gas Calibration</p> <p>O2 - Oxygen Calibration</p> <p>O3 - Ozone</p> <p>PROPANE - Propane Calibration</p> <p>PROPYLENE - Propylene (C3H6) Calibration</p>

Ordering Code: (Example)

FGI 30
05
06
F110P
AC115
AIR

Remark:
Remote style including 7.5 m cable (Standard)

"Specify Mix" = Require percentage concentration of each gases

Pipe ID must be at least two inch (2") for insertion style

Ordering Information

iSOLV In-line Style Thermal Mass Flowmeter

(Example)		
FGL 30	Model	
	FGL 30	- In-line Integral
	FRL 30	- In-line Remote
	FGL 90	- In-line Integral
	FRL 90	- In-line Remote
025	In-line Style Flow Bodies	
	025	- 1/4" In-line Flow Body, 6" Length
	030	- 3/8" In-line Flow Body, 6" Length
	050	- 1/2" In-line Flow Body, 7" Length
	075	- 3/4" In-line Flow Body, 7" Length
	100	- 1" In-line Flow Body, 8" Length
	125	- 1-1/4" In-Line Flow Body, 10" Length
	150	- 1-1/2" In-Line Flow Body, 12" Length
	200	- 2" In-line Flow Body, 12" Length
	250	- 2-1/2" In-line Flow Body, 12" Length
	300	- 3" In-line Flow Body, 12" Length
	400	- 4" In-line Flow Body, 12" Length
F103	In-line Style Flanged Ends	
	0	- Without Flange
	F103	- 150lb ANSI Raised-Face SS Flanged Ends, 3/8"
	F105	- 150lb ANSI Raised-Face SS Flanged Ends, 1/2"
	F107	- 150lb ANSI Raised-Face SS Flanged Ends, 3/4"
	F110	- 150lb ANSI Raised-Face SS Flanged Ends, 1"
	F114	- 150lb ANSI Raised-Face SS Flanged Ends, 1-1/4"
	F115	- 150lb ANSI Raised-Face SS Flanged Ends, 1-1/2"
	F120	- 150lb ANSI Raised-Face SS Flanged Ends, 2"
	F125	- 150lb ANSI Raised-Face SS Flanged Ends, 2-1/2"
	F130	- 150lb ANSI Raised-Face SS Flanged Ends, 3"
	F140	- 150lb ANSI Raised-Face SS Flanged Ends, 4"
	F305	- 300lb ANSI Raised-Face SS Flanged Ends, 1/2"
	F307	- 300lb ANSI Raised-Face SS Flanged Ends, 3/4"
	F310	- 300lb ANSI Raised-Face SS Flanged Ends, 1"
	F314	- 300lb ANSI Raised-Face SS Flanged Ends, 1-1/4"
	F315	- 300lb ANSI Raised-Face SS Flanged Ends, 1-1/2"
	F320	- 300lb ANSI Raised-Face SS Flanged Ends, 2"
	F325	- 300lb ANSI Raised-Face SS Flanged Ends, 2-1/2"
	F330	- 300lb ANSI Raised-Face SS Flanged Ends, 3"
	F340	- 300lb ANSI Raised-Face SS Flanged Ends, 4"
AC115	Power	
	AC115	- 115VAC Operating Power (field switchable to 230VAC)
	AC230	- 230VAC Operating Power (field switchable to 115VAC)
	DC24	- 24 VDC Operating Power (Customer Supplied)
AIR	Gas	
	AIR	- Air Calibration
	AR	- Argon Calibration
	BIOGAS	- Biogas (Specify Mix)
	BUTANE	- Butane Calibration
	CH4	- Methane Calibration
	CL2	- Chlorine Calibration
	CO	- Carbon Monoxide Calibration
	CO2	- Carbon Dioxide Calibration
	DIGGAS	- Digester Gas (Specify Mix)
	ETHYLENE	- Ethylene Gas Calibration
	FLAREGAS	- Flare Gas (Specify Mix)
	FLUEGAS	- Flue Gas (Specify Mix)
	H2	- Hydrogen Calibration
	H2S	- H2S Gas (Dry) Calibration
	HE	- Helium Calibration
	LFG	- Landfill Gas Calibration (Specify Mix)
	MIX	- Mixture Calibration (Specify Mix)
	N2	- Nitrogen Calibration
	NG	- Natural Gas Calibration
	NH3	- Ammonia Gas Calibration
	O2	- Oxygen Calibration
	O3	- Ozone
	PROPANE	- Propane Calibration
	PROPYLENE	- Propylene (C3H6) Calibration

Ordering Code: (Example)

FGL 30 **025** **F103** **AC115** **AIR**

Remark:
Remote style including 7.5 m cable (Standard)

Larger flange connection is available, please contact Flotech

"Specify Mix" = Require percentage concentration of each gases

Ordering Information

iSOLV Thermal Mass Flowmeter Accessories Options

(Example)

HPO

HPO	- High Pressure Operation (500 to 1000 PSIG)
HPO2	- Very High Pressure Operation (1500 PSIG) Includes Flange
HSEINLINE	- Hastelloy Sensor Within 316 SS In-Line Meters
HSEININSERTION	- Hastelloy Sensor & Probe (Insertion Meters)
HTO1	- High Temp Operation - Up to 175°C (Std Sensor Only to 90°C)
HTO2	- Very High Temperature Operation - Up to 230°C
ID	- Stainless Steel ID Tag
HART	- HART communication (for 90 series only)
CALCERT	- Calibration Certificate
CBL0050	- Non-Std Cable Length for Remote Meters - 15 m
CBL0075	- Non-Std Cable Length for Remote Meters - 20 m
CBL0100	- Non-Std Cable Length for Remote Meters - 30 m
CBL0125	- Non-Std Cable Length for Remote Meters - 35 m
CBL0150	- Non-Std Cable Length for Remote Meters - 45 m
CBL0200	- Non-Std Cable Length for Remote Meters - 60 m
CBL0250	- Non-Std Cable Length for Remote Meters - 75 m
CBL0300	- Non-Std Cable Length for Remote Meters - 90 m
CBL0350	- Non-Std Cable Length for Remote Meters - 105 m
CBL0500	- Non-Std Cable Length For Remote Meters - 150m
CBL0550	- Non-Std Cable Length For Remote Meters - 160m
CBL0750	- Non-Std Cable Length For Remote Meters - 225m
CBL1000	- Non-Std Cable Length For Remote Meters - 300m
FC1DIA0150	- Flow Conditioner Spool 1.5" X 1.5"L Captive In User Flange
FC1DIA0200	- Flow Conditioner Spool Piece 2"X2"L Captive in User Flange
FC1DIA0250	- Flow Conditioner Spool Piece 2-1/2"X2-1/2"L Captive in User Flange
FC1DIA0300	- Flow Conditioner Spool Piece 3"X3"L Captive in User Flange
FC1DIA0400	- Flow Conditioner Spool Piece 4"X4"L Captive in User Flange
FC1DIA0600	- Flow Conditioner Spool Piece 6"X6"L Captive in User Flange
FC1DIA0800	- Flow Conditioner Spool Piece 8"X8"L Captive in User Flange
FC1DIA0900	- Flow Conditioner Spool Piece 9"X9"L Captive in User Flange
FC1DIA1000	- Flow Conditioner Spool Piece 10"X10"L Captive in User Flange
FC1DIA1200	- Flow Conditioner Spool Piece 12"X12"L Captive in User Flange
FC1DIA1400	- Flow Conditioner Spool Piece 14"X14"L Captive in User Flange
FC1DIA1600	- Flow Conditioner Spool Piece 16"X16"L Captive in User Flange
FC1DIA1800	- Flow Conditioner Spool Piece 18"X18"L Captive in User Flange
FC1DIA2000	- Flow Conditioner Spool Piece 20"X20"L Captive in User Flange
FC1DIA2400	- Flow Conditioner Spool Piece 24"X24"L Captive in User Flange
FC1DIA2800	- Flow Conditioner Spool Piece 28"X28"L Captive in User Flange
FC1DIA3000	- Flow Conditioner Spool Piece 30"X30"L Captive in User Flange
FC1DIA3600	- Flow Conditioner Spool Piece 36"X36"L Captive in User Flange
STCF05	- 1/2" Compression Fitting Teflon Ferrule - 125PSIG
SSCF05	- 1/2" Compression Fitting SS Ferule - 650 PSIG
STCF07	- 3/4" Compression Fitting Teflon Ferrule -125PSIG
SVA05	- 1/2" X 3/4" Isolation Valve Assembly With Safety Chain
SVA07	- 3/4" X 1" Isolation Valve Assembly With Safety Chain
SSCF07	- 3/4" Compression Fitting SS Ferule - 650 PSIG

Ordering Code: (Example)

HPO

FLOTECH

PROCESS CONTROL & INSTRUMENTATION

REGIONAL NETWORK

SALES AND SERVICE CENTRES

CHINA

FLOTECH CONTROLS (SHANGHAI) CO., LTD
B-C, Songhu Industrial Zone, No.3
Yanghebang Road, Songjiang High-tech Park,
Shanghai, P.R.C (201615)
Tel: (86) 21 64593908
Fax: (86) 21 64595018
Email: info@flotechshanghai.com

福德控制仪器 (上海) 有限公司
地址: 上海松江高科技园区洋河浜路3号松沪工业小
区B区C栋
邮政编码: 201615
电话: (86) 21 64593908
传真: (86) 21 64595018
电子邮件: info@flotechshanghai.com

INDONESIA

PT FLOTECH CONTROLS INDONESIA
Komplek Rukan Artha Gading Niaga
Blok F/7, Jln. Boulevard Artha Gading
Jakarta 14240, Indonesia
Tel: (62) 21 4585 0778
Fax: (62) 21 4585 0779
Email: salesjkt@flotech.co.id

Branch Office Pekanbaru
Tel : (62) 761 674 839
Fax : (62) 761 678 295

MALAYSIA

M - FLOTECH CONTROLS SDN BHD
No. 20, Jalan TP 7/6
Taman Perindustrian UEP Subang Jaya
40400 Shah Alam
Selangor Darul Ehsan
Malaysia
Tel: (60) 3 5192 5325/6
Fax: (60) 3 5192 5327
Email: sales@mflotech.com.my

SINGAPORE - HEAD OFFICE FLOTECH CONTROLS PTE LTD

438 Tagore Industrial Avenue
Singapore 787814
Tel: (65) 6553 0366
Fax: (65) 6553 0828
Email: info@flotech.com.sg
Website: www.flotech.com.sg
www.isolv.biz
Reg. No.198204457H



Certificate SG95/04276



Certificate SG13/04547

