

DeZURIK 4" (100mm) & LARGER PEC ECCENTRIC PLUG VALVES TECHNICAL SPECIFICATIONS

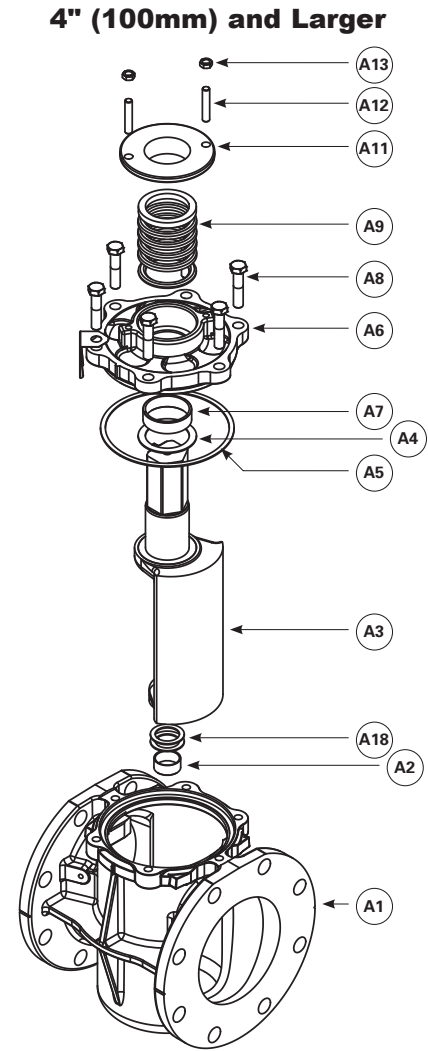

Materials of Construction

Item	Description	Material
A1	Body	Cast Iron, ASTM A126, Class B
		Ductile Iron, ASTM A536, Grade 65-45-12
		Acid Resistant Bronze, ASTM B427 Alloy C90700
		Carbon Steel, ASTM A216, Grade WCB
		316 Stainless Steel, ASTM A743, Grade CF-8M
		Alloy 20
		Hastelloy C
		Monel
		Aluminum, ASTM B26, Alloy 7130, Temper T5
		Cast Iron Hard Rubber Lined (flanged with NRH or NRCR plug facing only)
		Cast Iron Soft Rubber Lined (flanged with CR plug facing only)
		A2
316 Stainless Steel, ASTM A743, Grade CF-8M 20-36" (500-900mm) only		
A3	Plug	Metal (same metal as valve body except cast iron which has 316 stainless steel plug)
		CR Chloroprene
		NBR Acrylonitrile-Butadiene
		NRH Hard Natural Rubber (CIH Body Material only)
		CIIR Chloro-Isobutene Isoprene
		NRCR Hard Rubber with Chloroprene Overlay (CIH Body Material only)
		FKM Fluoro Rubber
		NBRD Acrylonitrile-Butadiene
EPDM Ethylene Propylene Diene Terpolymer		
A4	Grit Excluder	PTFE
A5	Gasket	Non-asbestos filler in Styrene-Butadiene Rubber binder
A6	Bonnet	Same material as body
A7	Bonnet Bearing	316L Stainless Steel, Sintered Stainless Steel 4-18" (100-450mm) only
		316 Stainless Steel, ASTM A743, Grade CF-8M 20-36" (500-900mm) only
A8	Bonnet Screws	Carbon Steel, Grade 2, Zinc Plated (CI, ABZ, NR Body Materials)
		Carbon Steel, Grade 5, Zinc Plated (CS Body Material)
		18-8 Stainless Steel (S2, AA, HC, ML Body Materials)
A9	Packing	NBR Acrylonitrile-Butadiene, V-Type
A11	Gland	Cast Iron on all except Stainless Steel
A12	Gland Stud	Zinc Plated on all except Stainless Steel
A13	Nut	Stainless Steel
		Carbon Steel, Zinc Plated
A18	Grit Excluder	PTFE (not included on CIS valve)



Applicable Standards

DeZURIK PEC Eccentric Plug Valves are designed and/or tested to meet the following standards:	
ASME B16.1, ASME B16.5, ASME B16.42	ASME flange drilling conforms to ASME B16.1 Class 125, ASME B16.5 Class 150, and ASME B16.42 Class 150.
AWWA C517-16	AWWA C517-16 Eccentric Plug Valves.
AWWA C111/A21.11	Mechanical-joint end connections conform to AWWA C111/A21.11.
AWWA C606	Grooved joint end connections conform to AWWA C606.
MSS-SP91	MSS-SP91 guidelines for manual operation of valves.
ISO 2084, British Standard 4504, DIN 2532	Metric 10 bar flange drilling conforms to the NP 10 requirements of International Standard ISO 2084, to the 10 bar requirements of British Standard 4504, and to the NP 10 requirements of German Standard DIN 2532.
ISO 2084, British Standard 4504, DIN 2533	Metric 16 bar flange drilling conforms to the NP 16 requirements of International Standard ISO 2084, to the 16 bar requirements of British Standard 4504, and to the NP 16 requirements of German Standard DIN 2533.
British Standard BS 10	British Table D flange drilling and Table E flange drilling conform to British Standard BS 10.
JIS B 0203	Japanese 10 bar flange drilling conforms to Japanese Industrial Standard JIS B 0203.

Cv/Kv Values

Valve Size	Cv* Kv*
4" 100mm	560 484
5 & 6" 125 & 150mm	1180 1020
8" 200mm	2030 1760
10" 250mm	3130 2710
12" 300mm	4140 3580
14" 350mm	5500 4760
16" 400mm	7300 6320
18" 450mm	9600 8300
20" 500mm	13000 11200
24" 600mm	17500 15100
30" 750mm	28000 24200
36" 900mm	40000 34600
42" 1100mm	58000 50200
48" 1200mm	100000 86500
54" 1400mm	100000 86500
66" 1700mm	150000 130000
72" 1800mm	150000 130000

NOTE: Cv/Kv values will be slightly higher for valves with threaded ends and for metal-to-metal seated valves. Sizing data is based on discharge into conduit rather than atmosphere.

* Cv = Flow in GPM of water at 1 psi pressure drop.

* Kv = Flow in m³/hr. of water at 100 kPa pressure drop.

Flow Characteristic

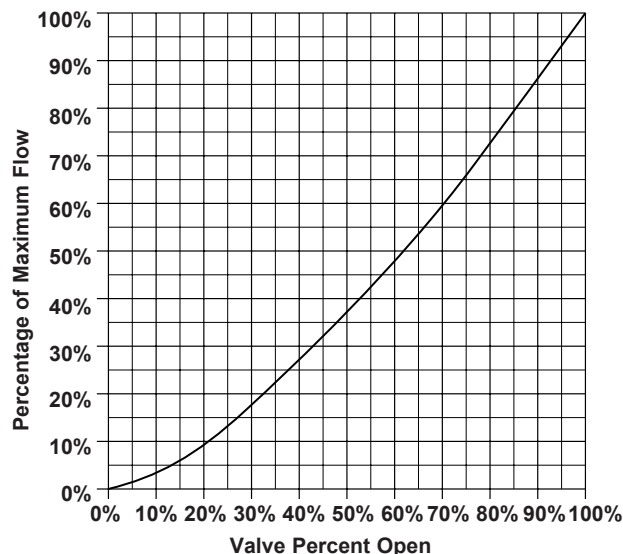

NOTE: To determine Cv at any position, multiply Cv at 100% open by factor on graph.

Valve Weights

Valve Size	Body Materials lb/kg				
	Cast Iron, Ductile Iron Flanged	Acid Bronze Flanged	Aluminum Flanged	Carbon Steel Flanged	Stainless Steel Flanged
4" 100mm	65 30	69 31	24 11	87 39	78 35
5 & 6" 125 & 150mm	110 50	120 54	38 17	141 64	133 60
8" 200mm	171 78	190 86	61 28	225 102	205 93
10" 250mm	250 113	265 120	95 43	350 159	270 122
12" 300mm	390 177	420 191	142 64	505 229	410 186
14" 350mm	555 252	580 263	197 89	720 327	625 284
16" 400mm	720 327	755 342	255 116	890 404	795 361
18" 450mm	1000 454	1025 465	315 143	1255 569	995 451
20" 500mm	1300 590	1360 617	470 213	1690 767	1565 710
24" 600mm	2790 1266	-	-	3015 1368	2895 1313
30" 750mm	5250 2381	-	-	4560 2068	4500 2041
36" 900mm	6550 2971	-	-	-	-
42" 1100mm	11500 5216	-	-	-	-
48" 1200mm	23000 10433	-	-	-	-
54" 1400mm	24000 10886	-	-	-	-
66" 1700mm	39000 17690	-	-	-	-
72" 1800mm	44000 19958	-	-	-	-

Note: Weights for 4-8" (100-200mm) include NT nut. Weights for all other actuators must be added.

Pressure Ratings

C.W.P. Non-Shock Working Pressure Ratings

Material	Valve Size		
	4-12" (100-300mm)	14-36" (350-900mm)	42-72" (1100-1800mm)
Cast Iron	175 psi 1210 kPa	150 psi 1035 kPa	150 psi 1035 kPa
Ductile Iron	285 psi 1965 kPa	250 psi 1724 kPa	250 psi 1724 kPa
Acid Resisting Bronze	200 psi 1380 kPa	150 psi 1035 kPa	-
Aluminum	150 psi 1035 kPa	125 psi 860 kPa	-
Carbon Steel**	285 Psi 1965 kPa	285 psi 1965 kPa	-
Stainless Steel** and other Alloys	275 psi 1896 kPa	275 psi 1896 kPa	-
Hard and Soft Rubber Lined Cast Iron* Body	175 psi 1210 kPa	150 psi 1035 kPa	-

* Cast Iron conforms to ASME B16.1 Class 125 Hydrostatic Test.

** Carbon Steel and 316 Stainless Steel conforms to ASME B16.5 Class 150.

*** Ductile Iron conforms to ASME B16.42 Class 150 hydrostatic test.

Valve Selection

Flow Charts

Valve Fully Open

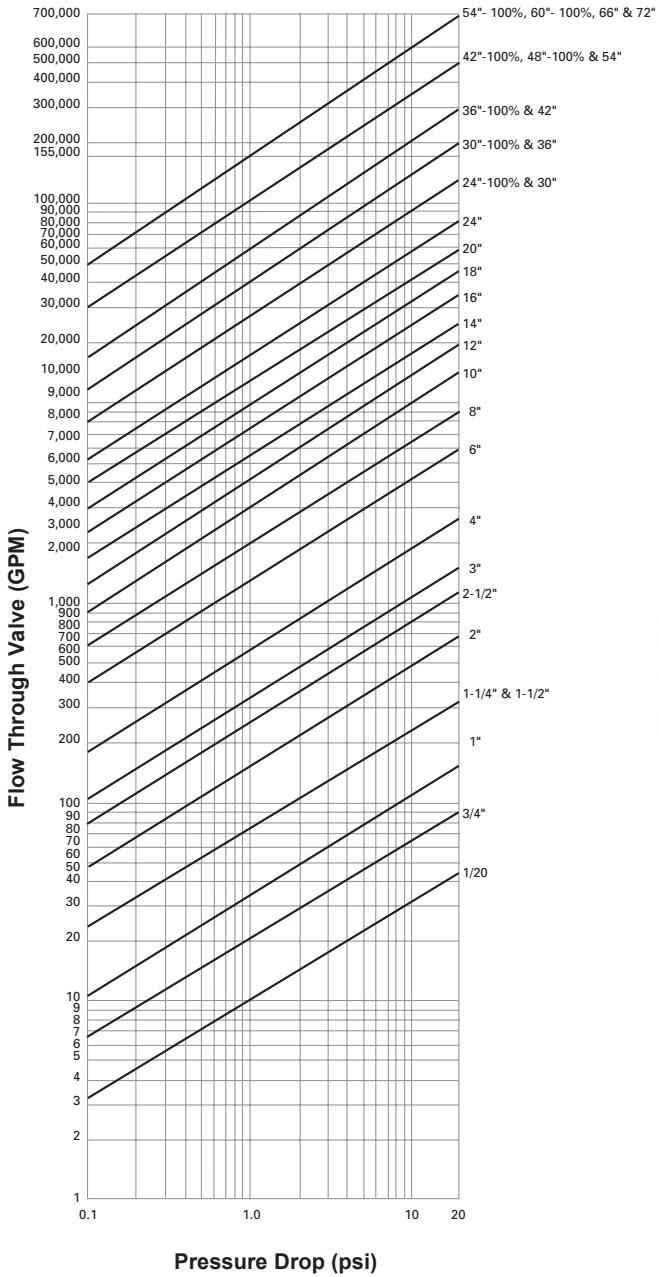

Valve Fully Open - Metric

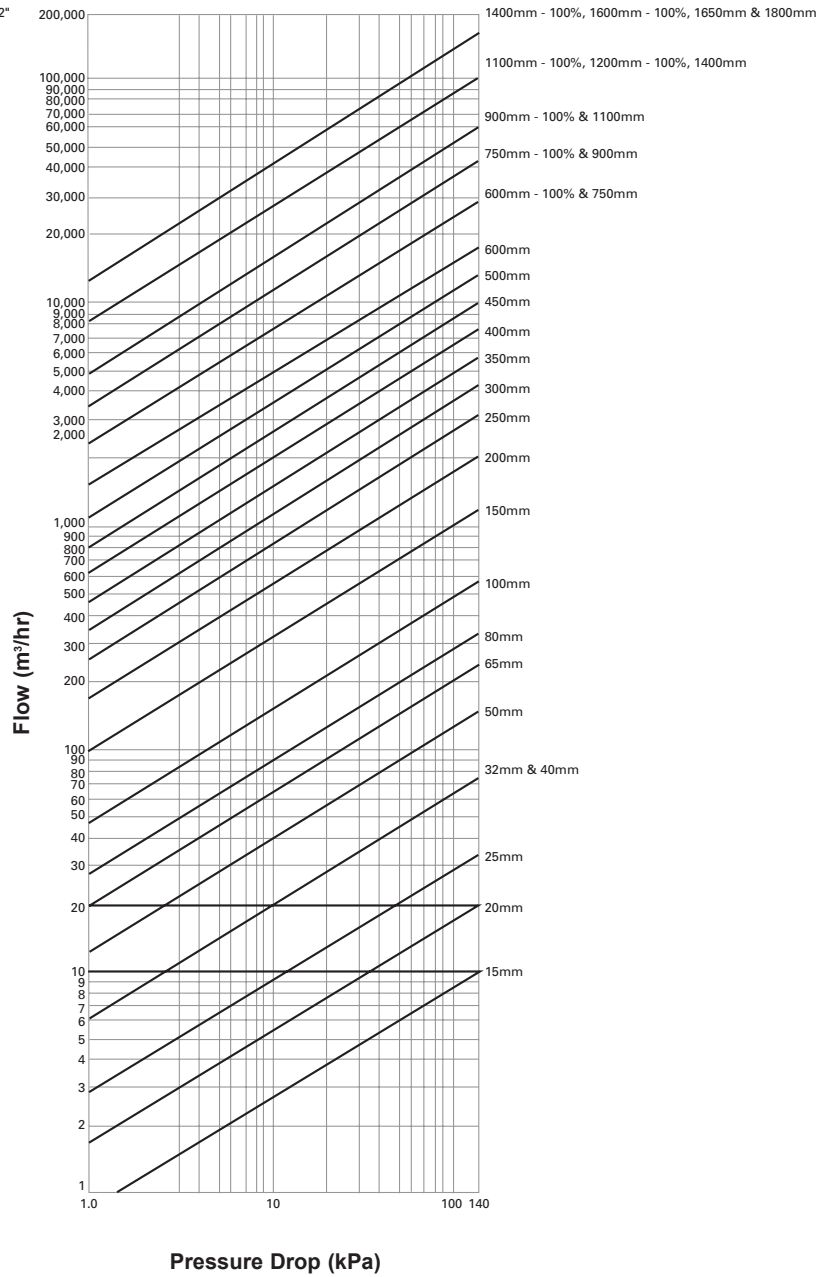

Installation Instructions

The type of materials carried in the pipeline and the location of the valve determine the correct installation procedure:

Liquids Without Suspended Solids and Clean Gases

1. Before installation, remove foreign material such as weld spatter, oil, grease, and dirt from the valve and pipeline.
2. Install the valve as shown in Figure 1.
3. Ensure the valve and flanges are concentric to ensure proper flange sealing.
4. Tighten the flange bolts or studs in a criss-cross pattern.

Figure 1

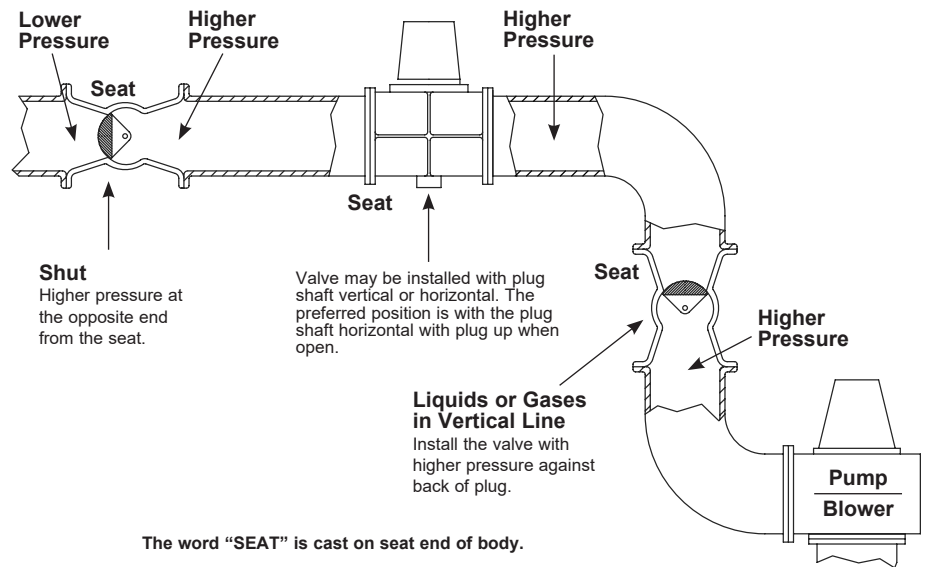

Suspended Solids and Dirty Gases

Figure 2

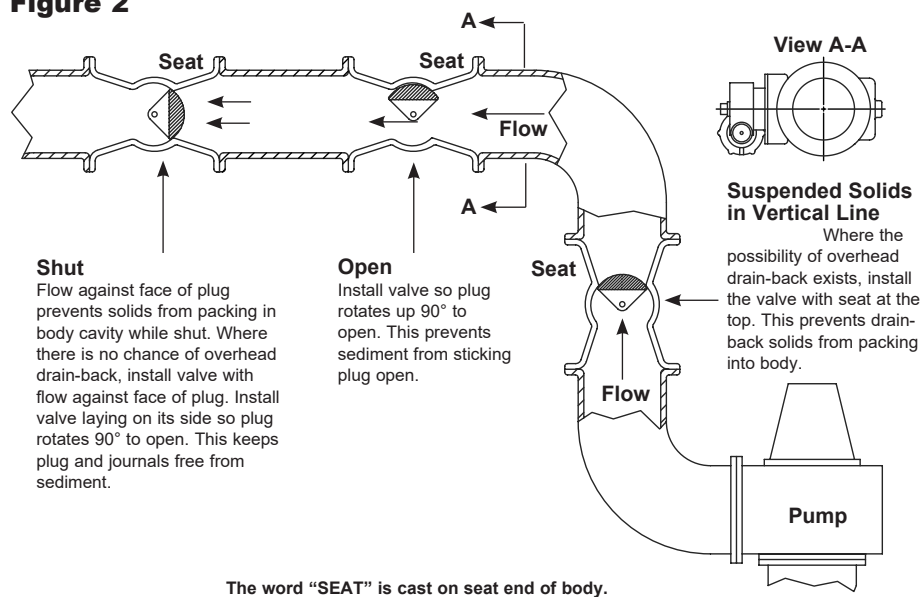

If the pipeline carries suspended solids such as paper stock of 2% or higher consistency, mining slurry, or raw sewage:

1. Before installation, remove foreign material such as weld spatter, oil, grease, and dirt from the valve and pipeline.
2. Install the valve as shown in Figure 2.
 - A. In horizontal pipelines install valve so plug is horizontal and rotates upward as valve opens.
 - B. For vertical pipelines, install valve with the end marked "Seat" at top of valve.
3. Tighten the flange bolts or studs in a criss-cross pattern.
4. Ensure the valve and flanges are concentric to ensure proper flange sealing.

FOR PUMP ISOLATION SERVICE, INSTALL THE VALVE WITH THE SEAT SIDE OPPOSITE THE PUMP AND WITH THE PLUG ROTATING TO THE TOP OF THE PIPELINE IN THE OPEN POSITION.

Ordering

To order, simply complete the valve order code from information shown. An ordering example is shown for your reference.

Valve Style

Give valve style code as follows:

PEC = Eccentric Plug

Valve Size

Give valve size code as follows:

4 = 4" (100mm)	24 = 24" (600mm)
5 = 5" (125mm)	30 = 30" (750mm)
6 = 6" (150mm)	36 = 36" (900mm)
8 = 8" (200mm)	42 = 42" (1100mm)
10 = 10" (250mm)	48.5 = 48.5" (1250mm)
12 = 12" (300mm)	54 = 54" (1400mm)
14 = 14" (350mm)	60.5 = 60.5" (1550mm)
16 = 16" (400mm)	66 = 66" (1675mm)
18 = 18" (450mm)	72 = 72" (1800mm)
20 = 20" (500mm)	

End Connection

Give end connection code as follows:

T1 = Threaded 4" CI Valves Only
F1 = Flanged, ANSI Class 125/150
F110 = Flanged, Class 150 DIN 10 or BS4504/10
F116 = Flanged, Class 150 DIN 16 or BS4504/16
F1D = Flanged, Class 150 BS Table D Drilling
F1E = Flanged, Class 150 BS Table E Drilling
F1J1 = Flanged, Class 150 JIS 10 Drilling
MJ = Mechanical Joint
V7 = Grooved Style 77, For steel and other metallic pipe per AWWA C606-15, Table 4
VF = Grooved Style 31, Flexible joint for ductile iron pipe per AWWA C606-15, Table 2
VR = Grooved Style 31, Rigid joint for ductile iron pipe per AWWA C606-15, Table 3

Body Material

Give body material code as follows:

CI = Cast Iron, Nickel Seat, 4-72" (100-1800mm)
DI = Ductile Iron, Nickel Seat, 4-72" (100-1800mm)
CIS = Cast Iron, Soft Rubber Lined (Flanged Only with CR plug facing)
DIS = Ductile Iron, Soft Rubber Lined (Flanged Only with CR plug facing)
ABZ = Acid Bronze
AL = Aluminum
CS = Carbon Steel, Nickel Seat, 4-36" (100-900mm)
S2 = 316 Stainless Steel
AA = Alloy 20
HC = Hastelloy C
ML = Monel
CIH = Cast Iron, Hard Rubber Lined (Flanged Only with NRH or NRCR plug facing)
CIPL = Cast Iron, Plastic Coated

Packing

Give packing code as follows:

NBR = Acrylonitrile-Butadiene V-Type Multiple V-Ring -20 to 250°F (-29 to 121°C)
NBRL = Acrylonitrile-Butadiene V-Type low friction 4-8" (100-200mm) NT actuators only -20 to 250° F (-29 to 121° C)
T = Solid PTFE to -20 to 450°F (-29 to 232° C)
SQ = Square Braided, -20 to 1000° F (-29 to 538° C)

Plug Facing

Give plug facing code as follows:

M = Metal (same metal as valve body except cast iron which has a stainless steel plug)
CR = Chloroprene -20 to 180° F (-29 to 83° C)
NBR = Acrylonitrile-Butadiene -20 to 180° F (-29 to 83° C)
NBRD = Acrylonitrile-Butadiene, 4-6" (100-150mm) only -20 to 180° F (-29 to 83° C)
NRH = Hard Natural Rubber CIH Bodies only -20 to 180° F (-29 to 83° C)
CIIR = Chloro-Isobutene Isoprene -20 to 250° F (-29° to 121° C)
NRCR = Hard Rubber with Chloroprene Overlay, use on CIH Body only -20 to 180° F (-29 to 83° C)
FKM = Fluoro Rubber -20 to 450° F (-29 to 232° C)
EPDM = Terpolymer of Ethylene Propylene & A Diene -20 to 250° F (-29 to 121° C)

Note:

The limiting factor in valve selection is the lowest temperature limit of the packing or seat.

Options

Give options codes as follows:

AIS = Valves conform to H.R. 3547 Consolidated Appropriations Act, 2014 Section 436. Available with CI, CIH, CIS, CS, DI, DIS, S2 Body Materials only
BAA = Buy American Act
BV1 = Balancing Valve with 1/8" air valve fittings, Available with CI or DI Body Material & F1 or V7 End Connection
BV2 = Balancing Valve with 1/8" quick disconnect couplings, Available with CI or DI Body Material & F1 or V7 End Connection
CMC = Certificate of Material Conformance
DI = Ductile Iron Plug (resilient plugs only)
DST = Dry Seat Test
DTR = DeZURIK Standard Certified Production Hydrostatic Shell & Seat Test Report
ST3 = Pennsylvania Steel Procurement Act
PD = 1/4" Pipe Tap Downstream
PU = 1/4" Pipe Tap Upstream
PDU = 1/4" Pipe Tap Upstream & Downstream, Available with CI Body Material and F1 & T1 End Connection only
GL = Glass Lining 4-24" (Ductile Iron Body Material Only), Available on CR & NBR plug facings only
GR = Grease Fittings in Body and Bonnet (except Rubber Lined Valves CIH, CIS & DIS). Not available with ENK extension
S2 = 316 Stainless Steel Plug (resilient plugs only)
TB_ = Certified Seat Leak Test Both Directions per AWWA C517
TD_ = Certified Seat Leak Test Direct Pressure per AWWA C517
TR_ = Certified Seat Leak Test Reverse Pressure per AWWA C517

Ordering Example:

PEC,4,F1,CI,NBR,CR,PD*GS-6-PC4

Nut (NT)

Furnished as standard on 4-8" (100-200mm) valves. Must be ordered to use VB, ENLV, EF, LV, CH, LVF, and WRT. To order, add code NT to basic valve code.

Direct or reverse shutoff pressure differentials for nut or lever actuated valves must not exceed the limits shown below. If valves must seal higher reverse pressure, use handwheel actuators. Handwheel or powered actuators are recommended on 6" (150mm) and larger valves as well as on applications where pipeline velocities are high and where sudden valve closure may cause water hammer.

Ordering Example:

PEC,4,F1,CI,NBR,CR*NT

Direct Pressure, Resilient Plug, Metal Seat

40lb Lever Pull

Valve Size	Packing	
	NBR, NBRL, SQ or T	
	Max. Shutoff Pressure Differential psi/kPa	
4" 100mm	25 170	
5" 125mm	25 170	
6" 150mm	25 170	

Direct Pressure, Resilient Plug, Metal Seat

80lb Lever Pull

Valve Size	Packing	
	NBR and T	NBRL and SQ
	Max. Shutoff Pressure Differential psi/kPa	
4" 100mm	125 850	40 275
5" 125mm	50 340	25 170
6" 150mm	50 340	25 170
8" 200mm	**50 340	**25 170

** Exceeds AWWA C517 input shaft torque limit

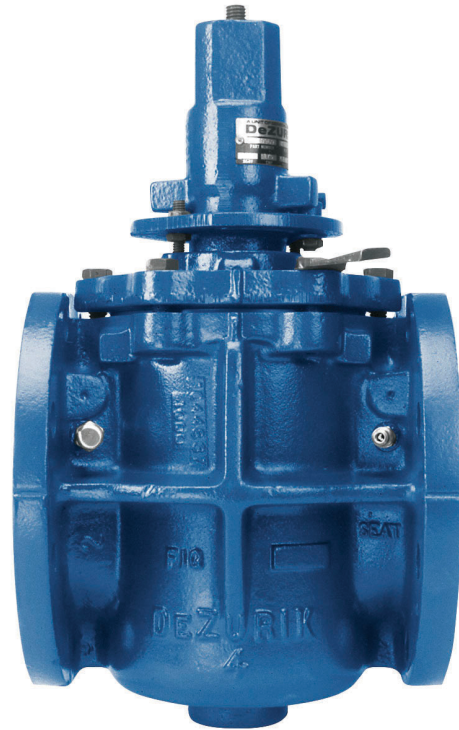

Direct Pressure, Metal Plug, Metal Seat or Hard Rubber Lined (CIH)
 Direct Pressure, Resilient Plug, Resilient Seat (CIS or DIS)
 Reverse Pressure, Resilient Plug, Metal Seat
 Reverse Pressure, Metal Plug, Metal Seat or Hard Rubber Lined (CIH)
 Reverse Pressure, Resilient Plug, Resilient Seat (CIS, DIS)
80lb Lever Pull

Valve Size	Packing	
	NBR and T	NBRL and SQ
	Max. Shutoff Pressure Differential psi/kPa	
4" 100mm	50 340	25 170
5" 125mm	25 170	25 170
6" 150mm	25 170	25 170
8" 200mm	**25 170	**25 170

** Exceeds AWWA C517 input shaft torque limit

Manual Actuators

Chain Handle (CH)

For use on 4-8" (100-200mm) valves with NT Nut. Chain Handle must be ordered separately by giving code ACC*CH followed by a dash and valve size.

Order Code	Size
ACC*CH-4	4" (100mm)
ACC*CH-5	5" (125mm)
ACC*CH-6	6" (150mm)
ACC*CH-8	8" (200mm)

Ordering Example:

ACC*CH-4

Chain for Chain Handle (CN)

Order as a separate item by giving code per chart. Specify number of feet required and number of pieces.

Order Code	Description
ACC*CN102	Standard 3/16
ACC*CN103	Galvanized 3/16
ACC*CN106	316 Stainless Steel

Ordering Example:

ACC*CN102

2 pieces, equal length
Qty: 20

G-Series Manual Actuators

G-Series manual actuators are totally enclosed and sealed, protecting moving parts from damage or corrosion. Continual lubrication is not required for operational ease. Heavy duty, corrosion-resistant actuator bearings provide lasting, easy valve operation and overall reliability. Rugged actuator castings, gears and shafts also add to reliability by assuring permanent alignment of moving parts for smooth operation.

To order, add the appropriate actuator code from the sizing tables to the valve order code.

Actuators can be mounted at 30° increments clockwise from standard except as noted in chart below.

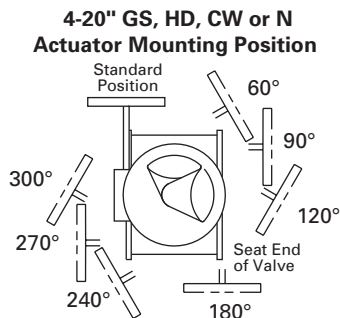

Adjustable Memory Stop

All 4-8" (100-200mm) lever actuated valves are furnished with an adjustable, open position memory stop as standard. Adjustment of the stop to the desired open position allows the valve to be closed and reopened to the same throttling position.

Lever (LV)

For use with NT actuators on 4-8" (100-200mm) valves. Lever must be ordered separately.

Order Code	Size
ACC*LV-4	4" (100mm)
ACC*LV-5	5" (125mm)
ACC*LV-6	6" (150mm)
ACC*LV-8	8" (200mm)

Ordering Example:

ACC*LV-4

Folding Lever (LVF)

For use with NT nut. Folding levers must be ordered separately.

Order Code	Size
ACC*LVF-4	4" (100mm)
ACC*LVF-5	5" (125mm)
ACC*LVF-6	6" (150mm)
ACC*LVF-8	8" (200mm)

Ordering Example:

ACC*LVF-6

2" Nut on GB & GS Actuators

The nut replaces the handwheel normally supplied on GB & GS actuators. A 2" nut is required for use with valve box (VB) or floor box (FB). To order replace the handwheel code with "N"

Ordering Example:

PEC,6,F1, CI,NBR,CR*GB-6-N-180

Buried/Submerged Handwheel Actuators

Similar to handwheel actuator except furnished with ductile iron gear sector, completely enclosed mounting bracket and actuator cover. To order, replace "GS" or "MG" in handwheel actuator number with "GB" or "MGB" (GS-6-HD8 to GB-6-HD8 or MG-WR1L-HD24 TO MGB-WR1L-HD24).

Ordering Example:

PEC,6,F1,CI,NBR*GB-6-HD8

Handwheel/Chainwheel Actuators

Direct Pressure, Resilient Plug, Metal Seat

Valve Size	Handwheel Order Code	Max. Shutoff Pressure Differential psi/kPa
4" 100mm	GS-6-HD8	285 1960
5-6" 125-150mm	GS-6-HD8	175 1210
	GS-6-HD12	285 1960
8" 200mm	GS-6-HD8	100 690
	GS-6-HD12	285 1960
10" 250mm	GS-6-HD8	50 340
	GS-6-HD12	125 860
	GS-12-HD12	175 1210
	GS-12-HD16	200 1960
12" 300mm	GS-6-HD8	25 170
	GS-6-HD12	75 520
	GS-12-HD12	100 690
	GS-12-HD16	150 1035
	GS-12-HD20	200 1380
14" 350mm	GS-12-HD12	50 340
	GS-12-HD16	75 515
	GS-12-HD20	125 860
	GS-12-HD24 ⁽¹⁾	150 1035
16" 400mm	GS-12-HD12	50 340
	GS-12-HD16	100 690
	GS-12-HD20	150 1030
	GS-12-HD24 ⁽¹⁾	175 1210
	MG-WR1L-HD32 ⁽³⁾	285 1960
18" 450mm	GS-12-HD12	50 340
	GS-12-HD16	75 520
	GS-12-HD20	100 690
	GS-12-HD24 ⁽¹⁾	125 860
	MG-WR1L-HD32 ⁽³⁾	200 1380
	MG-WR3L-HD32(3)	285 1960
20" 500mm	GS-12-HD12	25 170
	GS-12-HD16	50 340
	GS-12-HD20	75 520
	GS-12-HD24 ⁽¹⁾	100 690
	MG-WR1L-HD32 ⁽³⁾	150 1030
	MG-WR3L-HD32 ⁽³⁾	250 1720
24" 600mm	MG-WR1L-HD24 ⁽³⁾	50 340
	MG-WR3L-HD32 ⁽³⁾	150 1030
	MG-WR4L-HD24	250 1720
30" 750mm	MG-WR3L-HD32 ⁽³⁾	75 520
	MG-WR4L-HD36 ⁽³⁾	200 1380
	MG-WR5L-HD24 ⁽³⁾	250 1720
36" 900mm	MG-WR4L-HD32 ⁽³⁾	100 690
	MG-WR5L-HD32 ⁽³⁾	200 1380
	MG-WR6L-HD24 ⁽³⁾	250 1720

Valve Size	Chainwheel Order Code	Max. Shutoff Pressure Differential psi/kPa
4" 100mm	GS-6-CW8	285 1960
5-6" 125-150mm	GS-6-CW8	175 1210
	GS-6-CW12	285 1960
8" 200mm	GS-6-CW8	100 690
	GS-6-CW12	285 1960
10" 250mm	GS-6-CW8	50 340
	GS-6-CW12	125 860
	GS-12-CW12	175 1210
	GS-12-CW20	200 1960
12" 300mm	GS-6-CW8	25 170
	GS-6-CW12	75 520
	GS-12-CW12	100 690
	GS-12-CW20	200 1380
14" 350mm	GS-12-CW12	50 340
	GS-12-CW20 ⁽²⁾	125 860
	GS-12-CW30 ⁽¹⁾	150 1030
16" 400mm	GS-12-CW12	50 340
	GS-12-CW20	150 1030
	GS-12-CW30 ⁽¹⁾	175 1210
18" 450mm	MG-WR1L-CW30 ⁽³⁾	285 1960
	GS-12-CW12	50 340
	GS-12-CW20	100 690
	GS-12-CW30 ⁽¹⁾	125 860
20" 500mm	MG-WR1L-CW30 ⁽³⁾	200 1380
	MG-WR3L-CW30	285 1960
	GS-12-CW12	25 170
	GS-12-CW20	75 520
24" 600mm	GS-12-CW30 ⁽¹⁾	100 690
	MG-WR1L-CW30 ⁽³⁾	150 1380
	MG-WR3L-CW30	250 1720
	MG-WR1L-CW24 ⁽³⁾	50 340
30" 750mm	MG-WR3L-CW30 ⁽³⁾	150 1030
	MG-WR4L-CW24	250 1720
	MG-WR3L-CW30 ⁽³⁾	75 520
	MG-WR4L-CW30 ⁽³⁾	200 1380
36" 900mm	MG-WR5L-CW24 ⁽³⁾	250 1720
	MG-WR4L-CW30 ⁽³⁾	100 690
	MG-WR5L-CW30 ⁽³⁾	200 1380
	MG-WR6L-CW24 ⁽³⁾	250 1720

1 Available mounting positions: standard, 60, 180 and 240

2 Available mounting positions: standard, 60, 90, 180, 240 and 270

3 Available mounting positions: standard and 180

Ordering Example:

PEC,6,F1,C1,NBR,CR*GS-6-HD8

Manual Actuators

Handwheel/Chainwheel Actuators

Direct Pressure, Metal Plug, Metal Seat or Hard Rubber Lined (CIH)

Direct Pressure, Resilient Plug, Resilient Seat (CIS or DIS)

Reverse Pressure, Resilient Plug, Metal Seat

Reverse Pressure, Metal Plug, Metal Seat or Hard Rubber Lined (CIH)

Valve Size	Handwheel Order Code	Max. Shutoff Pressure Differential psi/kPa
4" 100mm	GS-6-HD8	285 1960
5-6" 125-150mm	GS-6-HD8	150 1030
	GS-6-HD12	285 1960
8" 200mm	GS-6-HD8	50 340
	GS-6-HD12	150 1030
	GS-12-HD12	285 1960
10" 250mm	GS-6-HD12	50 340
	GS-12-HD12	125 860
	GS-12-HD16	175 1210
	GS-12-HD20	250 1720
	GS-12-HD24 ⁽¹⁾	285 1960
12" 300mm	GS-12-HD12	50 340
	GS-12-HD16	100 690
	GS-12-HD20	150 1030
	MG-WR1L-HD16	150 1030
	GS-12-HD24 ⁽¹⁾	175 1210
14" 350mm	GS-12-HD12	25 170
	GS-12-HD16	50 340
	GS-12-HD20	75 520
	GS-12-HD24 ⁽¹⁾	100 690
	MG-WR1L-HD24	225 1550
16" 400mm	GS-12-HD16	25 170
	GS-12-HD2 ⁽¹⁾	50 340
	MG-WR1L-HD24	175 1210
18" 450mm	MG-WR3L-HD24	285 1960
	GS-12-HD20	25 170
	MG-WR1L-HD32 ⁽³⁾	150 1030
20" 500mm	MG-WR3L-HD32 ⁽³⁾	225 1550
	MG-WR1L-HD32 ⁽³⁾	100 690
	MG-WR3L-HD32 ⁽³⁾	150 1030
24" 600mm	MG-WR1L-HD24 ⁽³⁾	25 170
	MG-WR3L-HD32 ⁽³⁾	125 860
	MG-WR4L-HD32 ⁽³⁾	250 1720
30" 750mm	MG-WR3L-HD32 ⁽³⁾	50 340
	MG-WR4L-HD36 ⁽³⁾	150 1030
	MG-WR5L-HD32 ⁽³⁾	250 1720
36" 900mm	MG-WR4L-HD36 ⁽³⁾	75 520
	MG-WR5L-HD32 ⁽³⁾	150 1030
	MG-WR6L-HD32 ⁽³⁾	250 1720

Valve Size	Chainwheel Order Code	Max. Shutoff Pressure Differential psi/kPa
4" 100mm	GS-6-CW8	285 1960
5-6" 125-150mm	GS-6-CW8	150 1030
	GS-6-CW12	285 1960
8" 200mm	GS-6-CW8	50 340
	GS-6-CW12	150 1030
	GS-12-CW12	285 1960
10" 250mm	GS-6-CW12	50 340
	GS-12-CW12	125 860
	GS-12-CW20	250 1720
	GS-12-CW30 ⁽¹⁾	285 1960
12" 300mm	GS-12-CW12	50 340
	GS-12-CW20	150 1030
	MG-WR1L-CW20	150 1030
14" 350mm	GS-12-CW30 ⁽¹⁾	175 1210
	GS-12-CW12	25 170
	GS-12-CW20 ⁽²⁾	75 520
	GS-12-CW30 ⁽¹⁾	100 690
16" 400mm	MG-WR1L-CW24	225 1550
	GS-12-CW20	25 170
	GS-12-CW30 ⁽¹⁾	50 340
18" 450mm	MG-WR1L-CW24	175 1210
	MG-WR3L-CW24	285 1960
	GS-16-CW20	25 170
20" 500mm	MG-WR1L-CW30 ⁽³⁾	150 1030
	MG-WR3L-CW30	225 1550
	MG-WR1L-CW30 ⁽³⁾	100 690
24" 600mm	MG-WR3L-CW30 ⁽³⁾	150 1030
	MG-WR1L-CW24 ⁽³⁾	25 170
	MG-WR3L-CW30 ⁽³⁾	125 860
30" 750mm	MG-WR4L-CW30	250 1720
	MG-WR3L-CW30 ⁽³⁾	50 340
	MG-WR4L-CW30 ⁽³⁾	150 1030
36" 900mm	MG-WR5L-CW30 ⁽³⁾	250 1720
	MG-WR4L-CW30 ⁽³⁾	75 520
	MG-WR5L-CW30 ⁽³⁾	150 1030
	MG-WR6L-CW30 ⁽³⁾	250 1720

1 Available mounting positions: standard, 60, 180 and 240

2 Available mounting positions: standard, 60, 90, 180, 240 and 270

3 Available mounting positions: standard and 180

Ordering Example:

PEC,6,F1,Ci,NBR,CR*GS-6-CW12

Handwheel/Chainwheel Actuators

Reverse Pressure, Resilient Plug and Resilient Seat (CIS or DIS)

Valve Size	Handwheel Order Code	Chainwheel Order Code	Max. Shutoff Pressure Differential psi/kPa
4" 100mm	GS-6-HD8	GS-6-CW8	285 1960
5-6" 125-150mm	GS-6-HD8	GS-6-CW8	150 1030
	GS-6-HD12	GS-6-CW12	250 1720
8" 200mm	GS-12-HD12	GS-12-CW12	285 1960
	GS-6-HD12	GS-6-CW12	125 860
	GS-12-HD12	GS-12-CW12	225 1550
10" 250mm	GS-12-HD20	GS-12-CW20	285 1960
	GS-12-HD12	GS-12-CW12	100 690
12" 300mm	MG-WR1L-HD16	MG-WR1L-CW20	225 1550
	GS-12-HD12	GS-12-CW12	75 520
14" 350mm	MG-WR1L-HD16	MG-WR1L-CW20	150 1030
	MG-WR1L-HD32(3)	MG-WR1L-CW30	200 1380

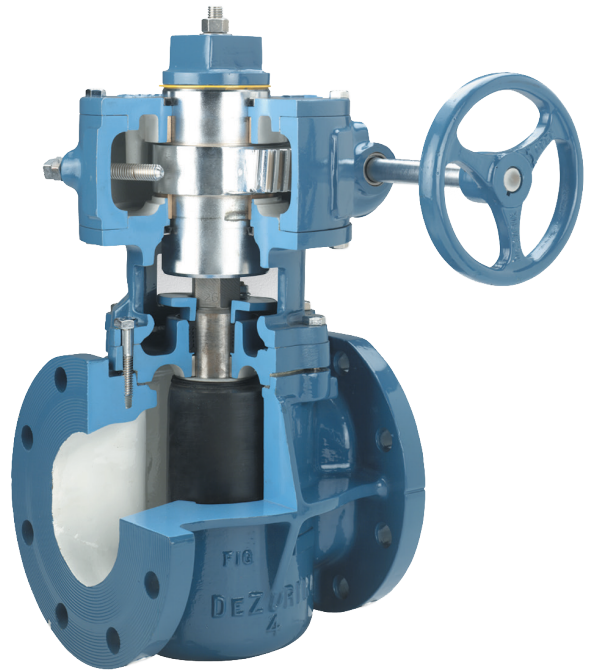

Ordering Example:

PEC,6,F1,CIS,NBR,CR*GS-6-HD8



Accessories-Manual Actuators

EF Extension for Nut Actuated Valves

For use on 4–8" (100–200mm) valves. Includes extension pipe, bearing plate and couplings. Valves for use with EF extensions must be ordered with NT actuators. Order Extension Assembly as a separate item. Specify length from centerline of valve to bottom of bearing plate. When ordering for use with FS101 Floor Stand, give dimension from centerline of valve to base of floor stand.

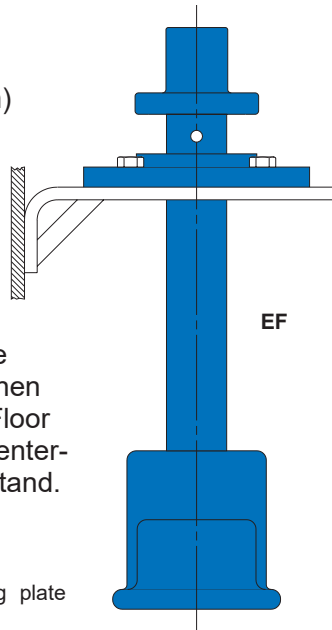

Ordering Example:

ACC*EF-4

Centerline of valve to bottom of bearing plate 110" (2795mm).

FSDIR or FSDIU Floor Stand for Gear Actuated Valves

For use on 4–36" (100–900mm) handwheel actuated valves. Includes floor stand, couplings, extension rod, and handwheel mounted on floor stand, with dial position indicator. Order floor stand by adding FSDIR or FSDIU to the valve actuator code.

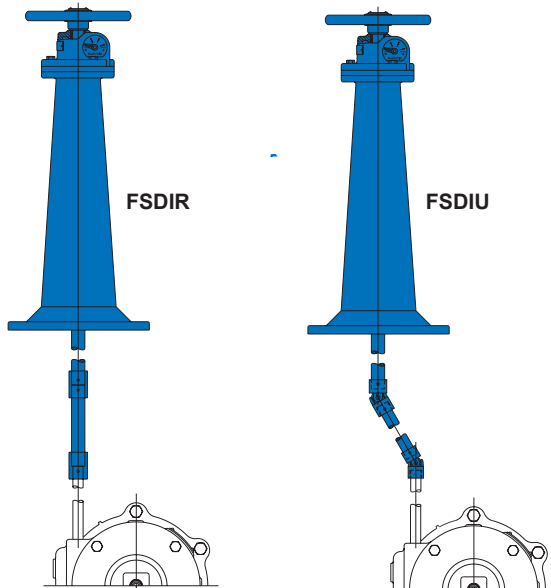

Ordering Example:

PEC,6,F1,CI,NBR,CR*GS-6-HD12,FSDIR

Centerline of valve to base of floor stand 96" (2400mm).

FB Floor Box for Nut Actuated Valves

Includes floor box and cover only. Can be used with valves having operating nut mounted on the valve or extended with top of nut 2" (50mm) from top of floor box. All valves for use with floor boxes are Tee Wrench actuated (order separately). Order extended operating nuts (ENLV) separately. Floor box requires NT actuators (order separately). Order floor boxes separately. Specify ACC*FB and depth of floor box in 1" (25mm) increments from 6–18" (150–455mm). Standard depth is 6" (150mm).

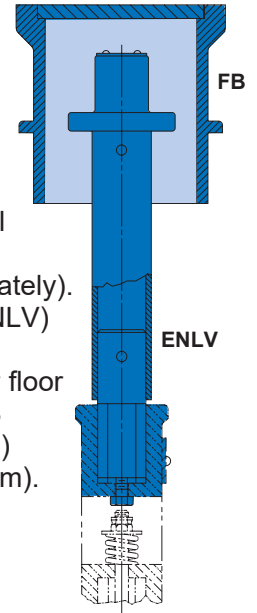

Ordering Example:

ACC*FB6

ENLV Extended Nut for Nut Actuated Valves

For use on 4–8" (100–200mm) nut actuated valves. Includes operating nut, couplings and pipe. Valves for use with ENLV Extended Nut must be ordered with NT actuators. All valves for use with ENLV are Tee Wrench activated (order separately). Order as a separate item by giving ACC*ENLV followed by a dash and valve size. Give required length from centerline of valve to top of nut.

Ordering Example:

ACC*ENLV-8

Centerline of valve to top of valve nut 126" (3200mm).

FS101 Floor Stand for Nut Actuated Valves

For use on 4–8" (100–200mm) nut actuated valves. Includes floor stand only. For extension pipe and fittings, order EF Extension Assembly. Lever actuated valves for use with EF Extension and FS101 Floor Stand must be ordered NT actuators. Order floor stands as a separate item.

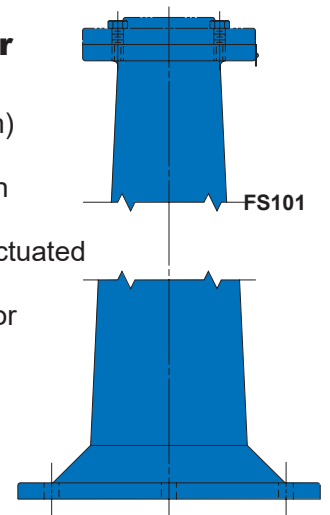

Ordering Example:

ACC*FS101

ENGS Extended 2" Nut for Gear Actuated Valves

The ENGS is for use on 4–36" (200–900mm) Eccentric Plug Valves with G-Series Handwheel Actuator. Includes couplings, extension rod and 2" square nut. If used with valve box, top of nut must be 6" below grade. If used with floor box, top of nut must be 2" below floor surface. Handwheels are not furnished on actuators ordered with ENGS. Order by adding ENGS to the valve actuator code. Specify required length from centerline of valve to top of nut as second line information.

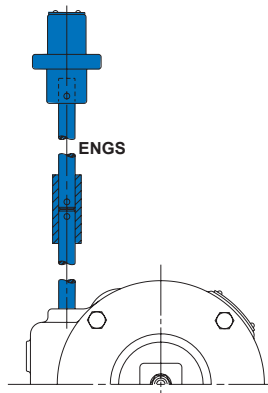

Ordering Example:

PEC,6,F1,CI,NBR,CR*GB-6-N,ENGS
Centerline of valve to top of nut 72" (1830mm).

WRT Tee Wrench

For use on 4–8" (100–200mm) nut or gear actuated valves with 2" square nut. Order Tee Wrenches as a separate item.

Wrench Length	Valve Size/Actuator Style		
	4-8" 100-200mm (NT)	4-8" 100-200mm (GS/GB)	10-36" 250-900mm (GS/GB/MG/MGB)
4 feet (1220mm)	ACC*WRT545	ACC*WRT540	ACC*WRT530
5 feet (1524mm)	ACC*WRT546	ACC*WRT541	ACC*WRT531
6 feet (1829mm)	ACC*WRT547	ACC*WRT542	ACC*WRT532
7 feet (2134mm)	ACC*WRT548	ACC*WRT543	ACC*WRT533
8 feet (2438mm)	ACC*WRT549	ACC*WRT544	ACC*WRT534

Stainless Steel Bolting

Specify bolting requirement by giving code SB18 for 18-8 Stainless Steel or SB16 for 316 Stainless Steel after the actuator code.

Ordering Example:

PEC,6,F1,CI,NBR,CR*GB-6-N,SB16

ENK Neck Extension for G-Series Actuators

Valves for buried or submerged service can be furnished with handwheel or cylinder actuators extended above the ground. Furnish service information for recommendations.

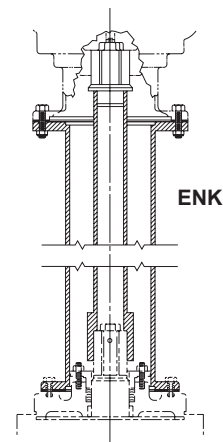

VB Valve Box for Nut Actuated Valves

Valve boxes for use on 4–8" (100–200mm) valves require a nut (NT) or extended nut (ENLV) type actuator. Valve boxes for use on 4–36" (100–900mm) valves with a gear actuator (GB) require a 2" (50mm) Nut (N) or extended 2" (50mm) Nut (ENGS) actuator. Extended nut must be 6" (150mm) from the top of the valve box. Order nut actuator and Tee Wrenches separately.

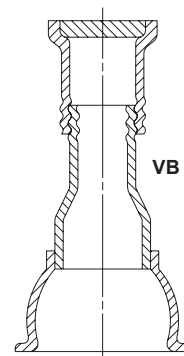

Horizontal plug valve installations require the plug to rotate to the top as the valve opens. Specify standard actuator mounting. Valve boxes and valve box extensions must be ordered separately. To order valve boxes, contact Application Engineering with valve size and specify length from centerline of valve to top of box (grade).

Cylinder Actuators

G-Series Cylinder Actuators

G-Series cylinder actuators feature a rack and pinion design for larger size rotary valves where constant torque capability throughout the stroke is required. It is engineered for high flow, high cycle applications. The G-Series line of actuators provides long service life and features a rugged, heavy cast gear sector. The cast iron actuator housing is sealed to prevent the entry of dirt, moisture and corrosive contaminants. The G-Series actuator also features adjustable position stops, rugged cylinder construction and corrosion-resistant bearings.

Double-Acting

To order double-acting cylinder actuators for PEC Eccentric Plug Valves, add the order code from the proper table to the valve order code. Actuators for 4–20" (100–500mm) valves can be mounted at 30 degree increments clockwise from standard. Specify mounting positions other than standard by adding the order code after the actuator. When using hydraulic supply media, specify type. Valves for gas service must be furnished with gear or cylinder actuator.

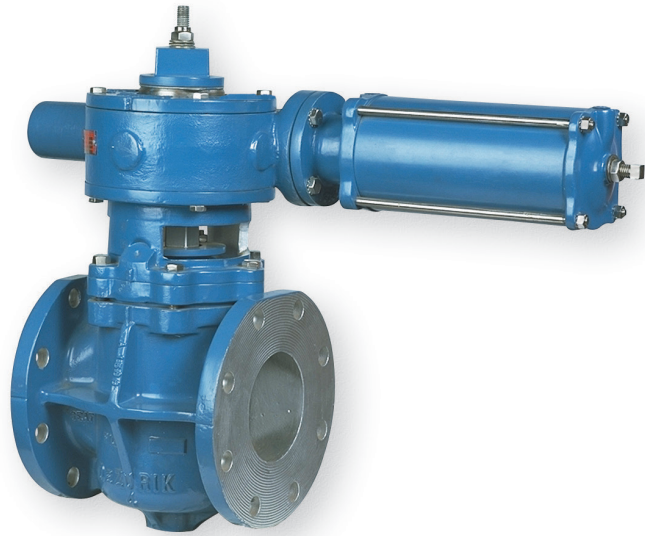

4-20" (100-500mm)
Actuator Mounting Position

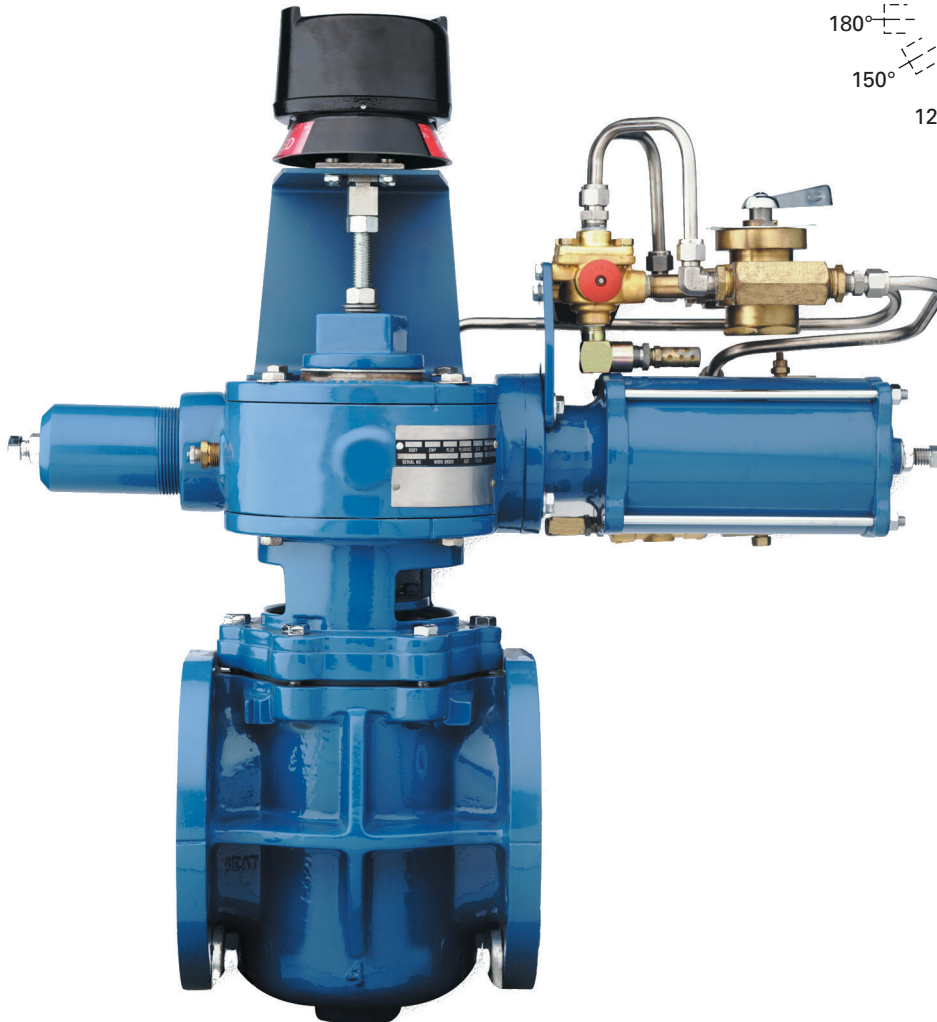
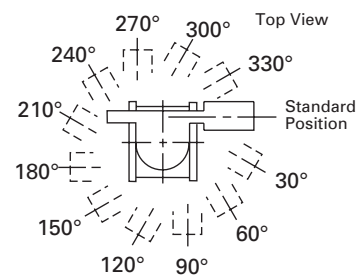

Double-Acting Cylinder Actuators Direct Pressure, Resilient Plug, Metal Seat 50 psi (340 kPa) Air Supply

Valve Size	Actuator Order Code	Max. Shutoff Pressure Differential psi/kPa
4" 100mm	GS-6-PC4	<u>285</u> 1960
5-6" 125-150mm	GS-6-PC4	<u>25</u> 170
	GS-6-PC6	<u>175</u> 1210
	GS-6-PC8	<u>285</u> 1960
8" 200mm	GS-6-PC6	<u>75</u> 520
	GS-6-PC8	<u>100</u> 690
	GS-12-PC6	<u>200</u> 1380
	GS-12-PC8	<u>285</u> 1960
10" 250mm	GS-6-PC6	<u>25</u> 170
	GS-6-PC8	<u>50</u> 340
	GS-12-PC6	<u>75</u> 520
	GS-12-PC8	<u>200</u> 1380
	GS-12-PC10	<u>285</u> 1960
12" 300mm	GS-6-PC8	<u>25</u> 170
	GS-12-PC8	<u>100</u> 690
	GS-12-PC10	<u>225</u> 1550
14" 350mm	GS-12-PC8	<u>25</u> 170
	GS-12-PC8	<u>50</u>
	GS-12-PC10	340
16" 400mm	GS-12-PC8	<u>50</u> 340
	GS-12-PC10	<u>75</u> 520
18" 450mm	GS-12-PC8	<u>25</u> 170
	GS-12-PC10	<u>50</u> 340
20" 500mm	GS-12-PC8	<u>25</u> 170
	GS-12-PC10	<u>50</u> 340

80 psi (550 kPa) Air Supply

Valve Size	Actuator Order Code	Max. Shutoff Pressure Differential psi/kPa
4" 100mm	GS-6-PC4	<u>285</u> 1960
5-6" 125-150mm	GS-6-PC4	<u>125</u> 860
	GS-6-PC6	<u>285</u> 1960
8" 200mm	GS-6-PC4	<u>25</u> 170
	GS-6-PC6	<u>100</u> 690
	GS-12-PC8	<u>285</u> 1960
10" 250mm	GS-6-PC6	<u>50</u> 340
	GS-12-PC6	<u>175</u> 1210
	GS-12-PC8	<u>285</u> 1960
12" 300mm	GS-6-PC6	<u>25</u> 170
	GS-12-PC6	<u>100</u> 690
	GS-12-PC8	<u>285</u> 1960
14" 350mm	GS-12-PC6	<u>50</u> 340
	GS-12-PC8	<u>125</u> 860
16" 400mm	GS-12-PC6	<u>25</u> 170
	GS-12-PC8	<u>75</u> 520
18" 450mm	GS-12-PC6	<u>25</u> 170
	GS-12-PC8	<u>50</u> 340
20" 500mm	GS-12-PC8	<u>50</u> 340

Cylinder Actuators

Double-Acting Cylinder Actuators

Direct Pressure, Metal Plug, Metal Seat or Hard Rubber Lined (CIS)

Reverse Pressure, Resilient Plug, Metal Seat or Metal Plug, Metal Seat

50 psi (340 kPa) Air Supply

Valve Size	Actuator Order Code	Max. Shutoff Pressure Differential psi/kPa
4" 100mm	GS-6-PC4	150 1035
	GS-6-PC6	285 1960
5-6" 125-150mm	GS-6-PC4	25 170
	GS-6-PC6	125 860
	GS-6-PC8	285 1960
8" 200mm	GS-6-PC6	50 340
	GS-6-PC8	125 860
	GS-12-PC6	175 1210
	GS-12-PC8	285 1960
10" 250mm	GS-6-PC8	50 340
	GS-12-PC6	75 520
	GS-12-PC8	150 1030
	GS-12-PC10	285 1960
12" 300mm	GS-12-PC6	25 170
	GS-12-PC8	75 520
	GS-12-PC10	175 1210
14" 350mm	GS-12-PC8	25 170
	GS-12-PC10	100 690
16" 400mm	GS-12-PC10	50 340
18" 450mm	GS-12-PC10	25 170

80 psi (550 kPa) Air Supply

Valve Size	Actuator Order Code	Max. Shutoff Pressure Differential psi/kPa
4" 100mm	GS-6-PC4	285 1960
	GS-6-PC6	285 1960
5-6" 125-150mm	GS-6-PC4	50 340
	GS-6-PC6	250 1720
8" 200mm	GS-6-PC6	125 860
	GS-12-PC6	285 1960
10" 250mm	GS-6-PC6	25 170
	GS-12-PC6	125 860
	GS-12-PC8	275 1890
12" 300mm	GS-12-PC6	75 520
	GS-12-PC8	175 1210
14" 350mm	GS-12-PC6	25 170
	GS-12-PC8	100 690
16" 400mm	GS-12-PC8	50 340
18" 450mm	GS-12-PC8	25 170

Ordering Example:

PEC,6,F1,CI,NBR,CR*GS-6-PC6

Double-Acting Cylinder Actuators Reverse Pressure, Soft Rubber Lined Valves (CIS) 50 psi (340 kPa) Air Supply

Valve Size	Actuator Order Code	Max. Shutoff Pressure Differential psi/kPa
4" 100mm	GS-6-PC4	50 340
	GS-6-PC6	285 1960
5-6" 125-150mm	GS-6-PC6	75 520
	GS-6-PC8	175 1210
8" 200mm	GS-6-PC8	75 520
	GS-12-PC6	100 690
	GS-12-PC8	250 1720
10" 250mm	GS-12-PC6	25 170
	GS-12-PC8	100 690
	GS-12-PC10	175 1210
12" 300mm	GS-12-PC8	50 340
	GS-12-PC10	100 690
14" 350mm	GS-12-PC10	50 340
16" 400mm	GS-12-PC10	25 170

80 psi (550 kPa) Air Supply

Valve Size	Actuator Order Code	Max. Shutoff Pressure Differential psi/kPa
4" 100mm	GS-6-PC4	175 1210
	GS-6-PC6	285 1960
5-6" 125-150mm	GS-6-PC4	25 170
	GS-6-PC6	150 1035
	GS-6-PC8	285 1960
8" 200mm	GS-6-PC6	50 340
	GS-6-PC8	150 1035
	GS-12-PC6	200 1380
	GS-12-PC8	285 1960
10" 250mm	GS-6-PC8	50 340
	GS-12-PC6	75 520
	GS-12-PC8	175 1210
12" 300mm	GS-6-PC8	25 170
	GS-12-PC6	50 340
	GS-12-PC8	100 690
14" 350mm	GS-12-PC8	50 340
16" 400mm	GS-12-PC8	25 170

Cylinder Actuators

Spring-Return Cylinder Actuators

To order spring-return cylinder actuators, add the order code from the proper chart to the basic valve order code. Actuators can be mounted at 30° increments clockwise from standard. Specify mounting positions other than standard by adding the order code after the actuator.

Actuator Mounting Position

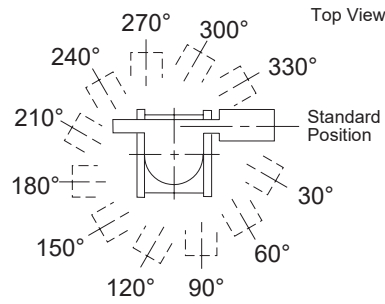

Direct Pressure Resilient Plug, Metal Seat

Spring-To-Close (Air-To-Open)
50 psi (340 kPa) Air Supply

Valve Size	Order Code	Max. Shutoff Pressure Differential psi/kPa
4" 100mm	GS-6-SC6	50 340
	GS-6-SC8	200 1380
5-6" 125-150mm	GS-6-SC8	25 170
	GS-12-SC10	150 1030
8" 200mm	GS-12-SC10	75 520
10" 250mm	GS-12-SC10	25 170

Spring-To-Open (Air-To-Close)
50 psi (340 kPa) Air Supply

Valve Size	Order Code	Max. Shutoff Pressure Differential psi/kPa
4" 100mm	GS-6-SC6-A	125 860
	GS-6-SC8-A	50 340
5-6" 125-150mm	GS-6-SC8-A	125 860
	GS-12-SC10-A	125 860
8" 200mm	GS-12-SC10-A	125 860
10" 250mm	GS-12-SC10-A	125 860
12" 300mm	GS-12-SC10-A	50 340

Ordering Example:

PEC,6,F1,CI,NBR,CR*GS-6-SC8-A

Direct Pressure, Metal Plug, Metal Seat or Hard Rubber Lined (CIH)

Direct Pressure, Soft Rubber Lined Valves (CIS or DIS)

Reverse Pressure, Resilient Plug, Metal Seat

Reverse Pressure, Metal Plug, Metal Seat or Hard Rubber Lined (CIH)

Spring-To-Close (Air-To-Open)
50 psi (340 kPa) Air Supply

Valve Size	Order Code	Max. Shutoff Pressure Differential psi/kPa
4" 100mm	GS-6-SC8	50 340
5-6" 125-150mm	GS-12-SC10	75 520
8" 200mm	GS-12-SC10	25 170

Spring-To-Open (Air-To-Close)
50 psi (340 kPa) Air Supply

Valve Size	Order Code	Max. Shutoff Pressure Differential psi/kPa
4" 100mm	GS-6-SC6-A	125 860
5-6" 125-150mm	GS-6-SC8-A	100 690
8" 200mm	GS-12-SC10-A	175 1210
10" 250mm	GS-12-SC10-A	75 520
12" 300mm	GS-12-SC10-A	25 170

Note: Contact the Application Engineer for actuator sizing for soft rubber lined valves when reverse pressure is greater than 25 psi (170 kPa). Furnish service conditions.

Accessories-Cylinder Actuators

Positioners

For use on all cylinder actuators. To order positioners, refer to bulletin 80.01-4.

3- & 4-Way Solenoid Valve (3V & 4V)

For use on cylinder actuators. To order solenoids, refer to bulletin 84.00-1.

4-Way Control Valve (CV)

For use on double-acting cylinder actuators. Order as a separate item by giving ACC* followed by appropriate 3-digit code from the table below. To order as part of a complete valve/actuator assembly, enter code from table below to the valve/actuator order code.

Pneumatic Actuators

Cylinder Size	NPT Size	Order Code
PC4 and PC6	.25" 6.4mm	CV201

Pneumatic or Hydraulic Actuators

Cylinder Size	NPT Size	Order Code
PC8 and PC10	.375" 9.5mm	CV202
PC12 and Larger	.5" 1mm	CV203

Ordering Example:

ACC*CV201 (separate item)

Ordering Example:

PEC,6,F1,CI,NBR,CR*GS-6-PC6,CV201

Position Indicating Switches (SEH)

For use on GS actuators. To order switches, refer to bulletin 83.00-1.

Air Filter Regulator (AFR2)

For use on all pneumatic actuators. To order, refer to bulletin 83.00-2.

Filter/Strainer

Filter for pneumatic actuators, strainer for hydraulic actuators. Order as a separate item per table below (not mounted).

Description	Order Code
Pneumatic Filter	ACC*FP
Hydraulic Strainer	ACC*FH

Ordering Example:

ACC*FH

Electric Motors

DeZURIK offers a variety of electric motor actuators on Eccentric Plug valves. When ordering, please specify valve function, installation location, line fluid, maximum fluid temperature, pipe connection, line size, normal and maximum working pressure, normal and maximum wide open valve flow, and flow range desired if throttling or modulating control.

Dimensions

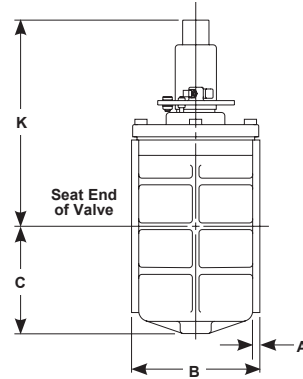
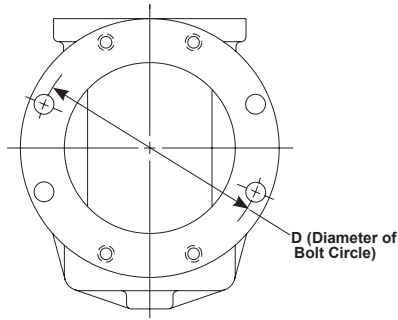

Basic Valve

CS=Carbon Steel, CI=Cast Iron, Ductile Iron, Bronze, Aluminum SST=Stainless Steel Alloys

Valve Size	A				B			C	D		
	Flanged			Mechanical Joint	Flanged	Mechanical Joint	Grooved		5" (125mm)	6" (150mm)	
	CS	CI*	SST								
4" 100mm	1.00 25	0.69 17	0.75 19	2.50 63	9.00 228	14.75 362	10.40 264	5.38 36	7.50 190		
5 & 6" 125 & 150mm	1.06 26	0.75 19	0.88 22	2.50 63	10.50 266	15.75 400	5" (125mm)	6" (150mm)	6.50 165	5" (125mm)	6" (150mm)
							12.50 318	12.88 327		8.50 215	9.50 241
8" 200mm	1.19 30	0.81 20	1.00 25	2.50 63	11.50 292	17.38 441	14.00 356	8.25 209	11.75 98		
10" 250mm	1.25 31	0.88 22	1.06 27	2.50 63	13.00 330	19.38 492	16.50 419	10.28 261	14.25 362		
12" 300mm	1.31 33	0.94 23	1.12 28	2.50 63	14.00 355	20.75 527	17.50 445	11.69 296	17.00 432		
14" 350mm	1.44 36	1.00 25	1.25 31	3.50 89	17.00 431	24.50 622	22.06 560	12.94 329	18.75 476		
16" 400mm	1.50 38	1.06 27	1.31 33	3.50 89	17.75 450	27.25 692	23.56 598	14.31 363	21.25 540		
18" 450mm	1.62 41	1.12 28	1.44 36	3.50 89	21.50 546	29.25 743	27.50 699	15.69 399	22.75 578		
20" 500mm	1.75 44	1.19 30	1.75 44	3.50 89	23.50 596	31.00 787	31.00 787	17.19 437	25.00 635		
24" 600mm	1.88 47	1.88 47	-	3.50 89	42.00 1067	42.00 1067	-	18.31 465	29.50 749		
30" 750mm	-	2.12 54	-	4.00 101	51.00 1295	51.00 1524	-	21.88 556	36.00 914		
36" 900mm	-	2.38 60	-	4.00 101	60.00 1524	60.00 1524	-	24.81 630	42.75 1086		
42" 1065mm	-	2.62 67	-	4.00 101	72.00 1829	74.00 1879	-	31.25 794	Flanged	Mechanical Joint	
									49.50 1257	50.62 1286	
48" 1200mm	-	2.81 71	-	4.00 101	84.00 2134	84.00 2134	-	40.00 1016	56.00 1422	57.50 1461	
54" 1370mm	-	3.06 78	-	-	96.00 2438	-	-	40.00 1016	62.75 1594	-	
66" 1675mm	-	3.43 87	-	-	115.00 2921	-	-	49.50 1257	76.00 1930	-	
72" 1830mm	-	3.56 90	-	-	125.00 3175	-	-	49.50 1257	82.50 2096	-	

Inch * Add .25/6.3 to A dimension for cast iron/rubber lined valves.
Millimeter

Nut Actuated Valves

Valve Size	K
4" 100mm	10.19 258
5" 125mm	13.81 350
6" 150mm	13.81 350
8" 200mm	15.38 390

Inch
Millimeter

Handwheel/Chainwheel Actuated Valves

Handwheel 4–20" (100–500mm)
GS-6-HD_ & GS-12-HD_

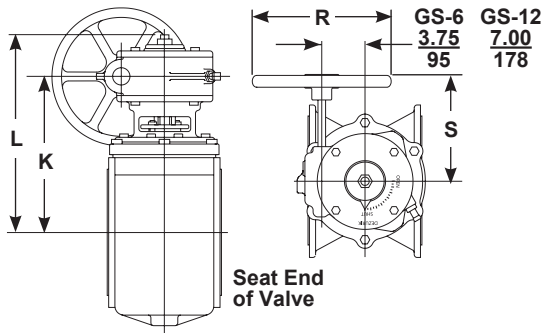

Chainwheel 4–20" (100–500mm)
GS-6-CW_ & GS-12-CW_

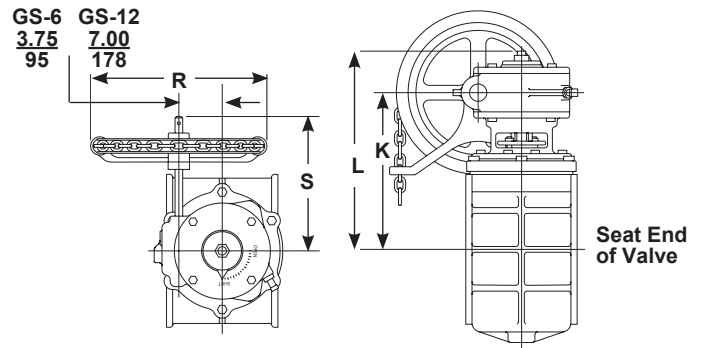

Valve Size	Actuator Code	K		L		R		S	
		HD	CW	HD	CW	HD	CW	HD	CW
4" 100mm	GS-6-HD-8 GS-6-CW_	9.62 245		13.27 338		8.00 203	10.06 256	6.88 174	8.81 224
5 & 6" 125 & 150mm	GS-6-HD_ GS-6-CW_	11.81 300		15.46 393		<u>8</u> 8.00 203	<u>12</u> 12.00 304	8.75 222	9.62 244
8" 200mm	GS-6-HD8 GS-6-CW8	13.63 347		17.28 340		8.00 203	10.06 256	8.75 222	9.62 244
	GS-6-HD12 GS-6-CW12	13.63 347		17.28 340		12.00 304	13.94 354	9.38 238	9.62 244
10" 250mm	GS-6-HD8 GS-6-CW8	15.12 384		18.77 477		8.00 203	10.06 256	11.12 282	11.88 302
	GS-6-HD12 GS-6-CW12	15.12 384		18.77 477		12.00 304	13.94 354	11.62 295	11.88 302
	GS-12-HD12 GS-12-CW12	15.74 400		19.39 493		12.00 304	13.94 354	17.88 454	17.38 441
	GS-12-HD16 GS-12-CW20	15.74 400		19.39 493		16.00 406	21.62 549	17.88 454	17.38 441
12" 300mm	GS-6-HD8 GS-6-CW8	16.75 426		20.40 519		8.00 203	10.06 256	11.88 301	
	GS-6-HD12 GS-6-CW12	16.75 426		20.40 519		12.00 304	13.94 354	12.88 314	11.88 302
	GS-12-HD12 GS-12-CW12	16.75 426		23.13 588		12.00 304	13.94 354	17.88 454	17.38 441
	GS-12-HD16 GS-12-CW20	16.75 426		23.13 588		16.00 406	21.62 549	18.25 464	17.38 441
	GS-12-HD20 GS-12-CW20	16.75 426		23.13 588		20.00 508	21.62 549	18.25 464	17.38 441

Dimensions

Handwheel/Chainwheel Actuated Valves (continued)

Valve Size	Actuator Code	K		L		R		S	
		HD	CW	HD	CW	HD	CW	HD	CW
14" 350mm	GS-12-HD12	18.74		25.12		12.00	13.94	17.88	17.38
	GS-12-CW12	476		638		305	354	454	441
	GS-12-HD16	18.74		25.12		16.00	21.62	18.25	17.38
	GS-12-CW20	476		638		406	549	464	441
16" 400mm	GS-12-HD20	18.74		25.12		20.00	21.62	18.25	17.38
	GS-12-CW20	476		638		508	549	464	441
	GS-12-HD24	18.74		25.12		24.00	31.46	22.25	17.38
	GS-12-CW30	476		638		610	799	565	441
18" 450mm	GS-12-HD12	20.24		26.62		12.00	13.94	17.88	17.38
	GS-12-CW12	514		676		305	354	454	441
	GS-12-HD16	20.24		26.62		16.00	21.62	18.25	17.38
	GS-12-CW20	514		676		406	549	464	441
20" 500mm	GS-12-HD20	20.24		26.62		20.00	21.62	18.25	17.38
	GS-12-CW20	514		676		508	549	464	441
	GS-12-HD24	20.24		26.62		24.00	31.46	22.25	17.38
	GS-12-CW30	514		676		610	790	565	441
18" 450mm	GS-12-HD12	21.12		27.50		12.00	13.94	17.88	17.38
	GS-12-CW12	536		699		305	354	454	441
	GS-12-HD16	21.12		27.50		16.00	21.62	18.25	17.38
	GS-12-CW20	536		699		406	549	464	441
20" 500mm	GS-12-HD20	21.12		27.50		20.00	21.62	18.25	17.38
	GS-12-CW20	536		699		508	549	464	441
	GS-12-HD24	21.12		27.50		24.00	31.46	22.25	17.38
	GS-12-CW30	536		699		610	799	565	441
20" 500mm	GS-12-HD12	23.12		29.50		12.00	13.94	17.88	17.38
	GS-12-CW12	587		749		305	354	454	441
	GS-12-HD16	23.12		29.50		16.00	21.62	18.25	17.38
	GS-12-CW20	587		749		406	549	464	441
20" 500mm	GS-12-HD20	23.12		29.50		20.00	21.62	18.25	17.38
	GS-12-CW20	587		749		508	549	464	441
	GS-12-HD24	23.12		29.50		24.00	31.46	22.25	17.38
	GS-12-CW30	587		749		610	799	565	441

Handwheel Actuated Valves 42-72" (1065-1830mm)

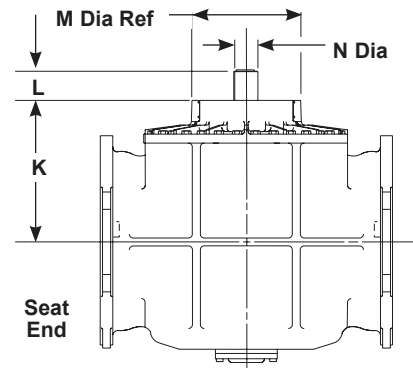
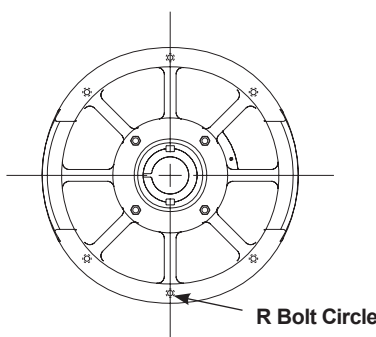
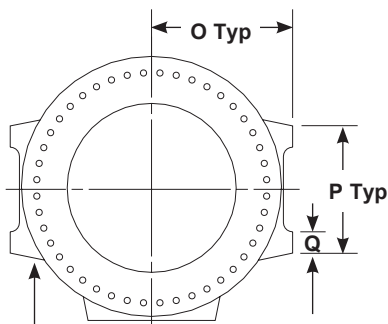

Valve Size	K	L	M	N	O	P	Q	R
42" 1065mm	34.81 884	10.50 267	34.50 876	6.50 165	27.25 692	28.00 711	4.00 102	32.00 813
48" 1200mm	44.94 1141	9.50 241	37.88 962	8.00 203	31.00 787	30.00 762	4.00 102	34.88 886
54" 1370mm	44.94 1141	9.50 241	37.88 962	8.00 203	34.37 873	32.00 813	4.00 102	34.88 886
66" 1675mm	52.81 1341	11.75 298	37.88 962	8.00 203	40.75 1035	36.00 914	6.00 152	34.88 886
72" 1830mm	52.81 1341	11.75 298	37.88 962	8.00 203	44.00 1118	38.00 965	6.00 152	34.88 886

Inch
Millimeter

For 4" (100mm) & larger 100% area valve information and 42" (1065mm) and larger chainwheel actuated valves, contact DeZURIK, Inc.

Cylinder Actuated Valves

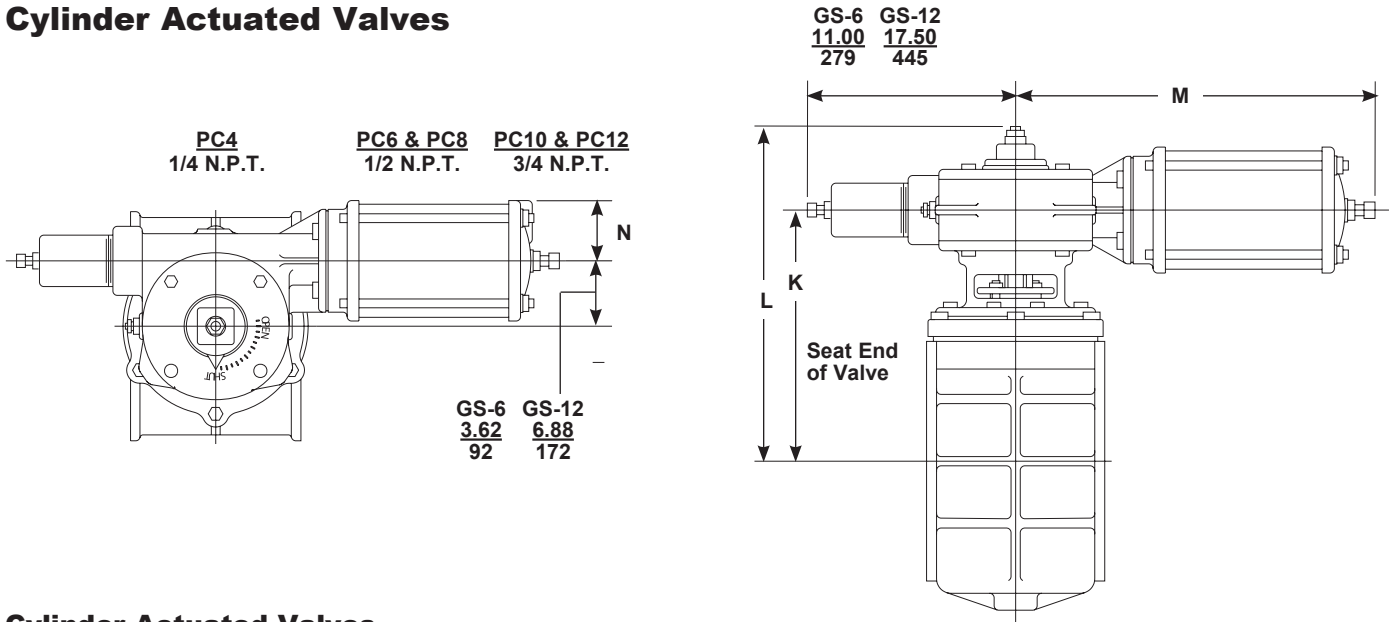

Cylinder Actuated Valves

Valve Size	Actuator Code	K	L	M			N				
				SC	PC		SC	PC			
4" 100mm	GS-6-PC4	9.44 240	14.32 364	-	18.88 480		-	2.19 56			
	GS-6-SC6 GS-6-PC6	9.62 245	14.50 369	30.00 762	19.12 485		5.12 130	3.19 81			
	GS-6-SC8	9.62 245	14.50 369	32.19 818	-		6.12 155	-			
5 & 6" 125 & 150mm	GS-6-SC6 GS-6-PC6	11.81 300	16.69 424	30.00 762	19.12 485		5.12 130	3.19 81			
	GS-6-SC8 GS-6-PC8	11.81 300	16.69 424	32.19 818	19.38 482		6.12 155	4.56 115			
	GS-6-SC6 GS-6-PC6	13.63 347	18.51 471	30.00 762	19.12 485		5.12 130	3.19 81			
8" 200mm	GS-6-SC8 GS-6-PC8	13.63 347	18.51 471	32.19 818	19.38 482		6.12 155	4.56 115			
	GS-12-SC10 GS-12-PC_	14.25 362	20.63 524	46.00 1168	PC6 30.56 776	PC8 30.88 784	PC10 31.00 787	7.43 188	PC6 3.26 82	PC8 4.25 108	PC10 5.25 133
	GS-6-SC6 GS-6-PC6	15.12 384	20.00 508	30.00 762	19.12 485		5.12 130	3.19 81			
10" 250mm	GS-6-SC8 GS-6-PC8	15.12 384	20.00 508	32.19 818	19.38 482		6.12 155	4.56 115			
	GS-12-SC10 GS-12-PC_	15.74 400	22.12 562	46.00 1168	PC6 30.56 776	PC8 30.88 784	PC10 31.00 787	7.43 188	PC6 3.26 82	PC8 4.25 108	PC10 5.25 133
	GS-6-SC6 GS-6-PC6	15.12 384	20.00 508	30.00 762	19.12 485		5.12 130	3.19 81			
12" 300mm	GS-6-SC8 GS-6-PC8	16.75 426	21.63 550	32.19 818	19.38 482	6.12 155	4.56 115	-	4.56 115		
	GS-12-SC10 GS-12-PC10	17.75 451	24.13 613	46.00 1168	PC6 30.56 776	PC8 30.88 784	PC10 31.00 787	7.43 188	PC6 3.26 82	PC8 4.25 108	PC10 5.25 133
	GS-6-SC6 GS-6-PC6	15.12 384	20.00 508	30.00 762	19.12 485		5.12 130	3.19 81			
14" 350mm	GS-12-PC_	18.74 476	25.12 638	-	PC6 30.56 776	PC8 30.88 784	PC10 31.00 787	-	PC6 3.25 82	PC8 4.25 108	PC10 5.25 133
		20.24 514	26.62 676	-	PC6 30.56 776	PC8 30.88 784	PC10 31.00 787	-	PC6 3.25 82	PC8 4.25 108	PC10 5.25 133
16" 400mm	GS-12-PC_	21.12 536	27.5 698	-	PC6 30.56 776	PC8 30.88 784	PC10 31.00 787	-	PC6 3.25 82	PC8 4.25 108	PC10 5.25 133
		23.00 584	29.38 746	-	PC6 30.56 776	PC8 30.88 784	PC10 31.00 787	-	PC6 3.25 82	PC8 4.25 108	PC10 5.25 133
18" 450mm	GS-12-PC_	21.12 536	27.5 698	-	PC6 30.56 776	PC8 30.88 784	PC10 31.00 787	-	PC6 3.25 82	PC8 4.25 108	PC10 5.25 133
		23.00 584	29.38 746	-	PC6 30.56 776	PC8 30.88 784	PC10 31.00 787	-	PC6 3.25 82	PC8 4.25 108	PC10 5.25 133
20" 500mm	GS-12-PC_	21.12 536	27.5 698	-	PC6 30.56 776	PC8 30.88 784	PC10 31.00 787	-	PC6 3.25 82	PC8 4.25 108	PC10 5.25 133
		23.00 584	29.38 746	-	PC6 30.56 776	PC8 30.88 784	PC10 31.00 787	-	PC6 3.25 82	PC8 4.25 108	PC10 5.25 133

Inch
Millimeter

Sales and Service

For information about our worldwide locations, approvals, certifications and local representative:

Web Site: DeZURIK.com **E-Mail:** info@DeZURIK.com



250 Riverside Ave. N. Sartell, Minnesota 56377 • Phone: 320-259-2000 • Fax: 320-259-2227

DeZURIK, Inc. reserves the right to incorporate our latest design and material changes without notice or obligation. Design features, materials of construction and dimensional data, as described in this bulletin, are provided for your information only and should not be relied upon unless confirmed in writing by DeZURIK, Inc. Certified drawings are available upon request.

AMS-KSEIndonesia Corp



PT. APINDO MITRA SELARAS

Serang Office :

Komp. Lebak Indah Griya Asri
Blok D4-D5 No.17 & No.05
Waringin Kuring - Kramatwatu
Serang, Banten
42161

Cilegon Office :

Jl. Raya Pondok Cilegon Indah
Ruko Cilegon City Square Blok I No.7
Kedaleman - Cibeber
Cilegon, Banten
42422

aris@kseindonesia.com - sales@kseindonesia.com - cso@kseindonesia.com

www.kseindonesia.com