

DeZURIK BHP HIGH PERFORMANCE BUTTERFLY VALVES



Time-Tested, Exceptional Performance

DeZURIK BHP High Performance Butterfly Valves are specially designed for applications in the chemical, hydrocarbon processing, pulp & paper, water & wastewater and HVAC industries worldwide. The valve was designed with an understanding that process industries need products that provide exceptional performance while reducing the total cost of ownership.

BHP butterfly valves have been rigorously tested to meet industry performance requirements. A fully supported one-piece shaft and heavy-duty bearings ensure perfect alignment of seat and disc leading to long life and trouble-free performance.

DeZURIK offers a wide variety of seat options including PTFE seat, reinforced PTFE seat, flexible metal seat and a dual seat.

DeZURIK BHP Butterfly Valves combine extreme service capabilities with features which have been time-tested for over 30 years.



Wafer or Lugged Body Styles

BHP butterfly valves are available in both lugged and wafer bodies in sizes 2–60" (50–1500mm). Body materials include Carbon Steel, 316 stainless steel, 317 stainless steel and higher alloys. In addition, DeZURIK regularly supplies valves in materials such as Hastelloy C, Monel, Alloy 20, and Titanium.

Material Certification

Materials chosen for the construction of the BHP butterfly valve are certified per ASME B16.34.

Face-To-Face Options

DeZURIK offers valve face-to-face dimensions in compliance with API 609, MSS SP-68 and ASME B16.1.

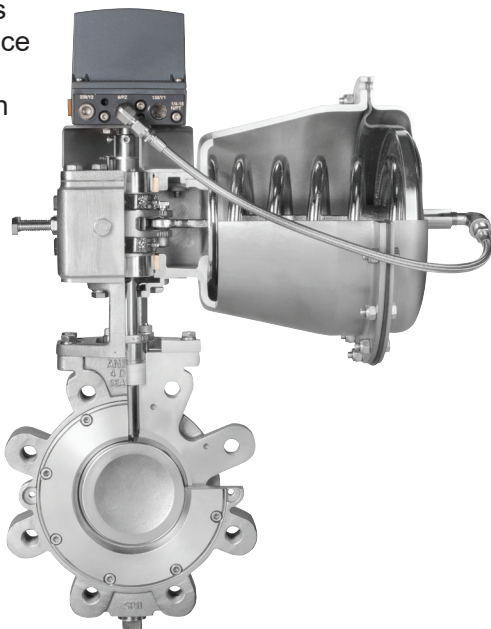

Flange Drilling Options

Flange drilling conformance to ASME 150, PN10/16 (ISO, DIN, BS, JIS) and ASME 300, PN25/40 (ISO, DIN, BS, JIS).

Full Bi-Directional Seating

Dual Seat, PTFE, and reinforced PTFE seats provide full bi-directional seating.

Dead-End Service

BHP lugged body style allows installation in dead-end service to the full pressure rating of the valve.

Flange Gasket Compatibility

Standard construction provides effective sealing with ASME B16.20 gaskets (formerly API 601). The standard seat retainer is drilled to meet the requirements of API 609 standard. As an option, an undrilled seat retainer is available to provide full gasket seal area contact. The seat retaining ring is nested in the valve body, providing support and protection for the seat and a captured blow-out resistant body-to-retainer seal.

Recommended for Critical Applications

BHP butterfly valves are designed to handle everything from general applications to viscous and corrosive liquids; corrosive gases; and steam. They have been successfully applied in extreme services, including:

- high temperature services
- cryogenic applications
- throttling steam control
- polymerizing media
- liquor service with entrained solids
- high cycle industrial gas
- process gas-off applications
- paper stock isolation
- vacuum pump isolation
- corrosive chemical service (titanium construction)
- fire-safe refinery & chemical service
- heat transfer service
- throttling hydrocarbon service

Proven Performance & Reliability

To ensure accurate and reliable performance, BHP butterfly valves have been tested to the most demanding industry specifications:

- Performance tested in up to 5% consistency pulp stock isolation.
- Tested for over 1 million cycles in oxygen manufacturing service with zero leakage.
- Fire tested to API 607, 6th edition.
- Tested in hydrogen peroxide service for over 75,000 cycles with zero leakage.
- Accuracy to repeat signal changes as small as 0.5% of total signal.

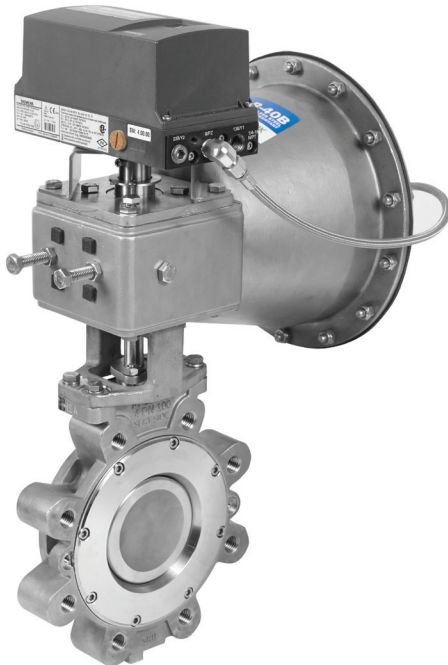

Offset Disc Design

The offset disc design provides uninterrupted 360° sealing surface. The offset disc also minimizes the amount of seat-to-disc interference, lowering operating torque, increasing cycle life, and reducing the size of actuators required. Smaller actuators reduce initial purchase price and use less energy over time.

One-Piece Stainless Steel Shaft

The solid one-piece stainless steel shaft provides superior strength and disc support. The extra support provided by the one-piece shaft enhances alignment, ensuring a proper seal.



Solid Disc-To-Shaft Pinning

DeZURIK uses a reliable method for disc-to-shaft pinning. The 2–12" (50–300mm) valves utilize a wedge-shaped, tangential pin with a locking taper to ensure a tight connection between disc and shaft. On 14" (350mm) and larger, two pins mounted in compression offer a non-shear method of locking. Both connections place the pin, shaft and disc in compression load providing a much stronger connection. This solid pinning ensures no lost motion between shaft and disc, an essential feature for a control valve. Set screws and pins are securely locked in place, but can be removed if repairs are necessary.

Disc Centered In Body/Seat

Close-tolerance machined surfaces between the body and disc hubs ensure proper alignment and seating.

Multiple Shaft Bearings

The valve shaft is fully supported with bearings for high cycle capability. Bearing options include PTFE backed with 317 stainless steel or Hastelloy C and solid metal (nickel stainless steel, 316 stainless steel). The bearings also provide a large area of radial support, greatly reducing any possibility of shaft fatigue and breakage. The bearing has a low coefficient of friction, minimizing operating torque.

NACE Trim

BHP butterfly valves meet the requirements of ASME/NACE MR0175/ISO 15156. NACE trim (NT) is optional when “NS” bearing material is ordered and standard on all other combinations. When ordered with the “NT” option, the bearing material is 316 stainless steel nickel-plated and heat-treated.

Ease of Maintenance

DeZURIK BHP valves are easily repairable. In the unlikely event that a seat, disc or bearing needs to be replaced, the valve can be easily disassembled. Internal valve components can be replaced or repaired in minutes, not hours. There are no welds to remove or pins to drill out, and all fasteners are common sizes. All that is required is to remove the screws fastening the retainer to the body and the screw that locks the disc-to-shaft pin.



Features For Extended Service Life

Extended service life is an important attribute when considering a valve for a given application. DeZURIK realizes installation and replacement costs, combined with the costs of a process shutdown, are expensive. That's why DeZURIK has always been dedicated to designing and manufacturing valves that last longer and perform better.

Metal Seated Valves Incorporate an Independent Static Seal

DeZURIK's Class IV and Class V metal seated valves have a gasket between the valve body, seat and seat retainer which provides an independent static seal. Without this seal, corrosion or pitting on the body or seat retainer could cause leakage around the seat. This is of particular concern in valves of carbon steel construction, or in applications where stainless steel is prone to pitting due to corrosive precipitation.

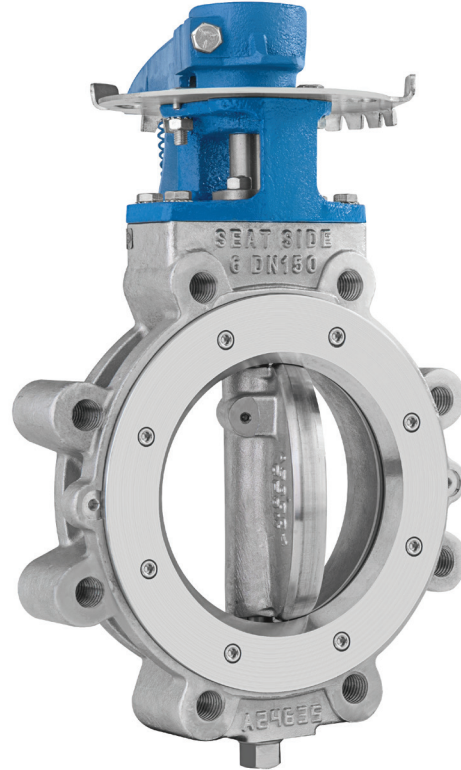

Compatible with Standard Actuators

High Performance Butterfly Valves are compatible with all DeZURIK standard actuators including levers, handwheels, chainwheels, PowerRac® cylinder, spring diaphragm, and Compak actuators.

Full Line of Accessories

Also available is a full line of accessories integrated with the actuator system including positioners, solenoids, switches, and speed controls.

Seat Designs

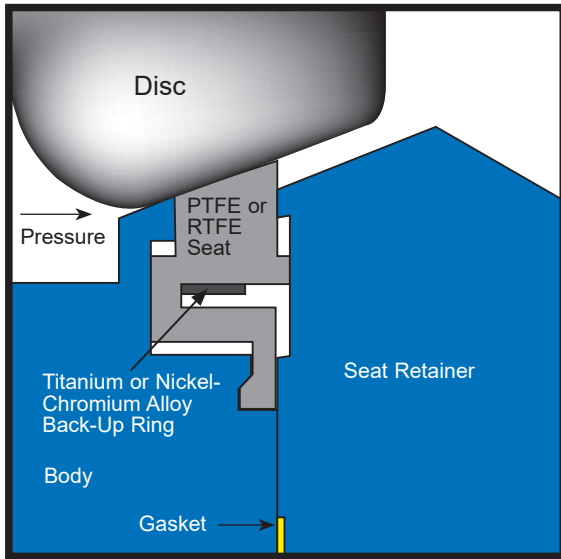

Spring & Pressure Assisted Soft Seats

Pressure assisted soft seats, in either PTFE and reinforced PTFE, offer bi-directional bubble tight shutoff. Soft seat options include either a titanium or nickel-chromium alloy back-up ring which utilizes hoop stress to provide memory for the seat.

The unique PTFE / RTFE design seals as well at low pressures as it does at high pressures. The soft seats also provide tight shutoff in vacuum service applications.

High-Temperature & Low-Temperature Metal Seats

For high-temperature applications to 700°F (370°C) as standard and to over 1000°F (538°C), a metal seat of 316 stainless steel provides ANSI/FCI 70-2 Class IV or V shutoff even at elevated temperatures. For increased economy in applications to 450°F (232°C), the metal seat can be specified with lower temperature bearings, packing and paint. The metal seat is electroless nickel coated and heat treated for superior service without the use of costly, exotic seating materials.

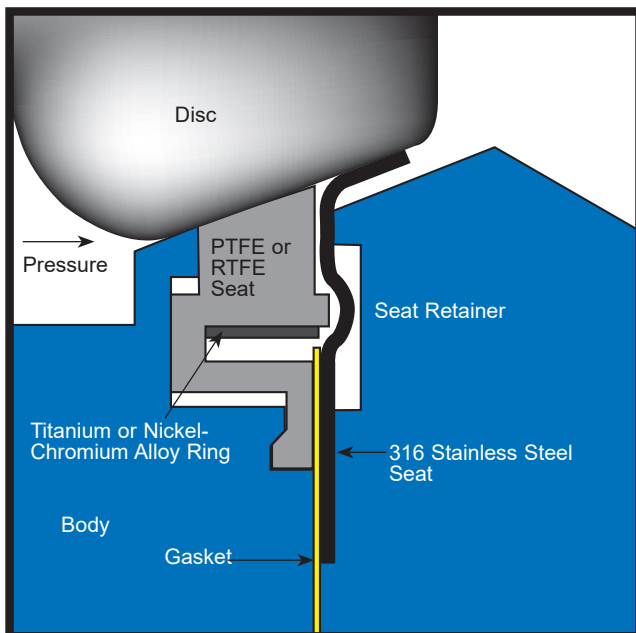
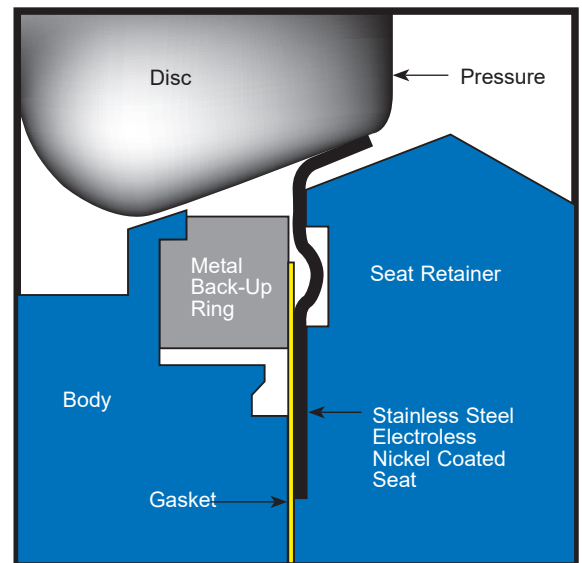

Dual Seat Design

The dual seat design is ideal for applications in which scaling media can solidify on the disc edge. The secondary metal seat wipes the disc edge, protecting the PTFE or RTFE seat. For services requiring a fire-tested valve, the Fyre-Block® option with dual seat combines a primary PTFE soft seat with a secondary 316 stainless steel metal seat. This dual, bi-directional seat design provides positive sealing even when the resilient seat has been destroyed by fire.

The Fyre-Block® option with dual seat design meets the API 607 standard, 6th Edition.

Special Construction Options

Fugitive Emissions Packing Systems

To enable manufacturers to meet clean air regulations, DeZURIK offers options for fugitive emissions control including live loaded and dual packing sets. Dual packing options feature a primary and secondary packing set, lantern ring and emissions sniffing port. When required, the packing gland can be live loaded with spring washers to maintain compression, even through extreme thermal cycling. Live loaded and dual packing options have been cycle tested per EPA method 21 and have been proven to provide long service life with emissions control well below Clean Air Act regulations of 500 parts per million. Live loaded packing and dual packing sets are available in the BHP butterfly valve with a bolt-on packing chamber.

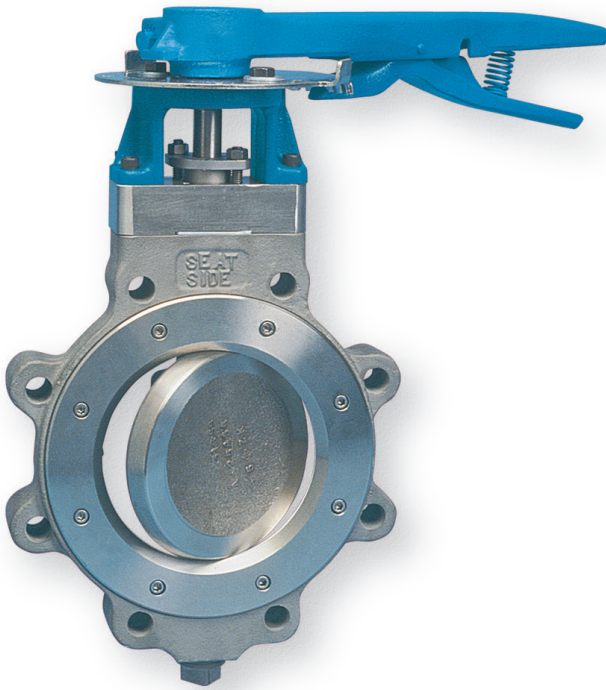

NSF/ANSI 61, 372 Certified for Drinking Water

DeZURIK BHP High Performance Butterfly Valves are specially designed for critical applications in the water industry, where high pressures, high velocity flows and stainless steel construction are required. When specified, DeZURIK BHP Valves are certified to meet the NSF/ANSI-61, 372 standard *Drinking Water Systems Components – Lead Content* which provides recognized safety in municipal water service.

Typical Water Applications

High Service Pumps:

- Transmission lines requiring NSF 61, 372 approval
- Pressures over 250 psi (1720 kPa)
- Pump isolation at pressures in excess of 250 psi (1720 kPa)
- Control Check service at pressures in excess of 300 psi (2070 kPa)

Typical Wastewater Applications

- Aeration lines in filter systems
- Oxygen and Ozone service

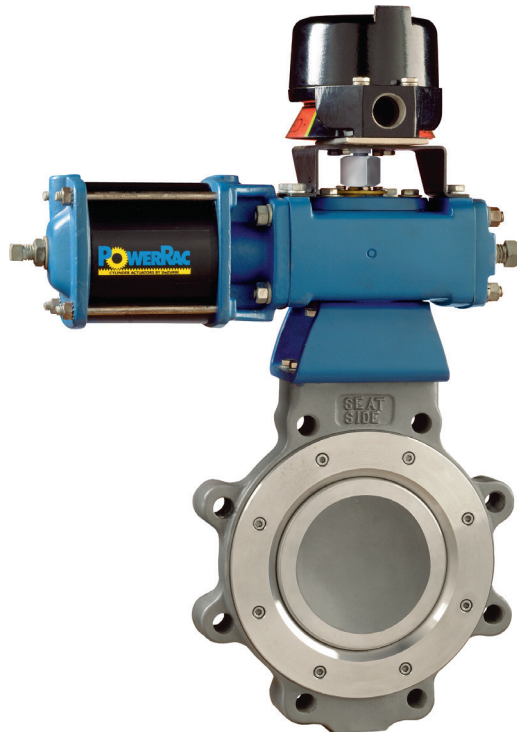

Fire-Tested Per API 607 Standard

The High Performance Butterfly Valve with Fyre-Block® FB construction and manual actuators are certified to API 607, 6th edition fire tests. Fyre-Block® valves offer a seat and seal design that provides positive sealing, even when the resilient material has been burned away. It is also certified to ISO 10497:2010.



BTG Tail Gas Butterfly Valves

DeZURIK has specially designed the Tail Gas High Performance Butterfly Valve to meet the rigorous requirements of services where polymerization or solidification of media can prevent valve operation, including: Tail gas service in refinery sulfur recovery units, polymer processing or adhesive manufacturing.

DeZURIK standard High Performance Butterfly Valves are available with standard steam jackets for less rigorous requirements, but Tail Gas Valves include unique features which keep the valve at process temperature and protect critical bearing and seat areas. In addition to steam jacketing the body, internal steam passage ports are located near the upper and lower body bearings. These features prevent hydrogen sulfide and other media from solidifying, freezing the bearings, damaging the seat and preventing tight shutoff. NACE trim is standard (NACE MR0175) with 316 stainless steel bearing.

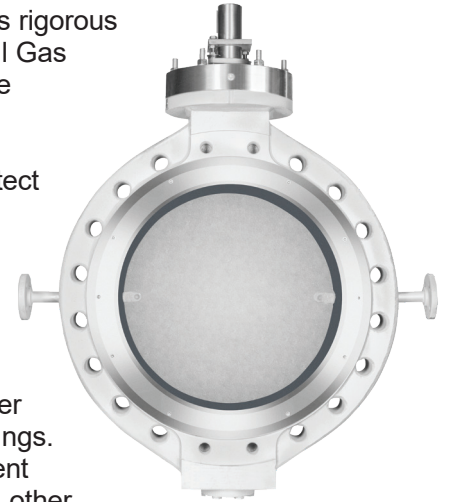

Critical Service Valve Cleaning & Packaging

Meeting the highest standards for special valve cleaning and packaging services is of paramount importance for DeZURIK. In order to ensure proper cleaning procedures are performed on BHP High Performance Butterfly valves intended for oxygen, ozone, chlorine, hydrogen peroxide, isocyanate and other applications, DeZURIK has constructed a dedicated clean room within its Sartell manufacturing plant. Our professional, skilled and trained cleaning technicians maintain a safe environment for a wide variety of cleaning services.



Materials of Construction

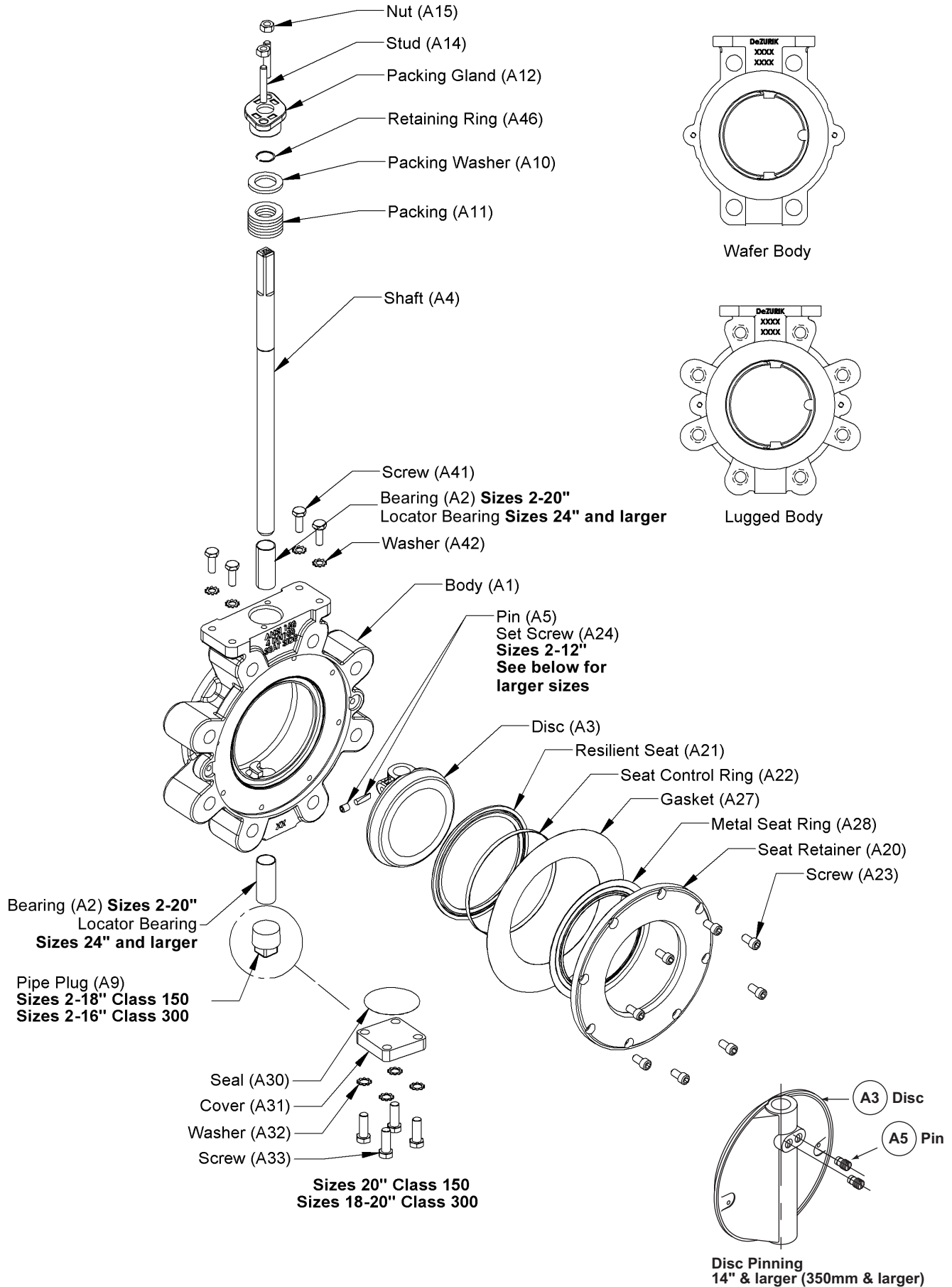

Packing Options

Standard

PTFE V-Flex Packing (TC)

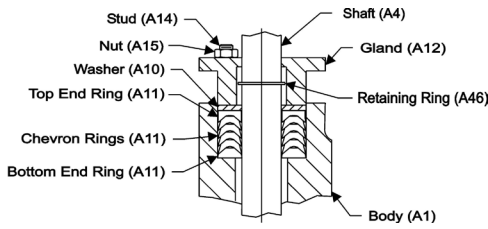

PTFE V-Flex Packing, Live Loaded, Low Cycle (TCL)

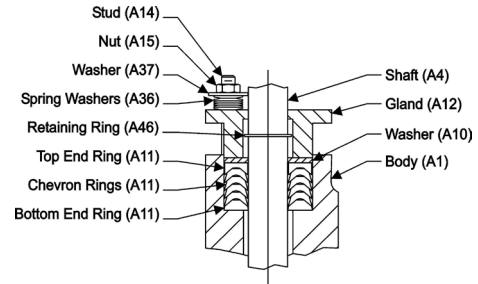

PTFE V-Flex, Dual Seal, Low Cycle Packing (TCD)

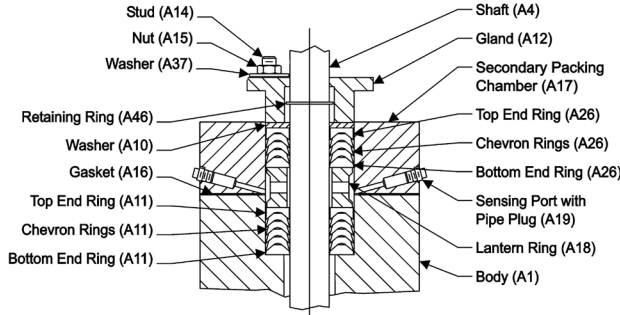

PTFE V-Flex, Dual Seal, Live Loaded, Low Cycle Packing (TCDL)

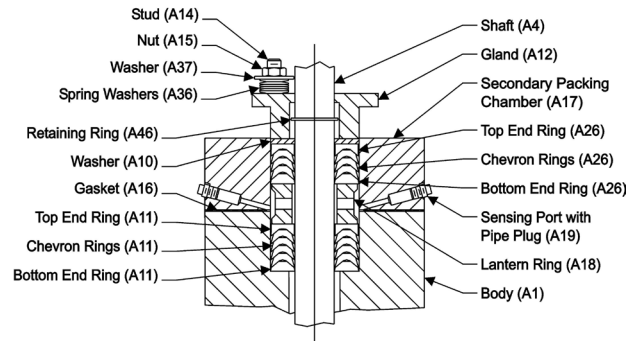

Standard Carbon Graphite (G1)

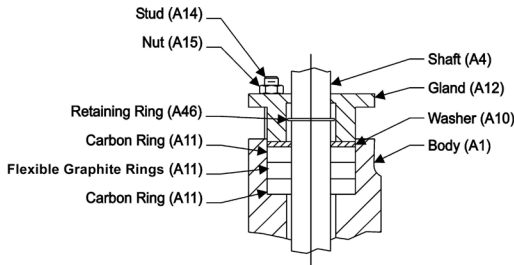

Flexible Carbon Graphite (G2)

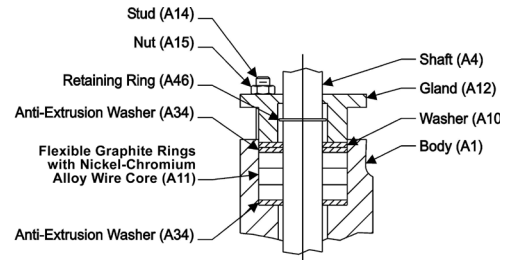

Flexible Carbon Graphite, High Cycle Live Loaded (G2L)

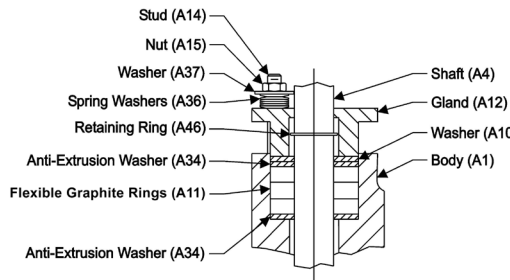

Flexible Carbon Graphite, Dual Seal, High Cycle Packing (G2D)

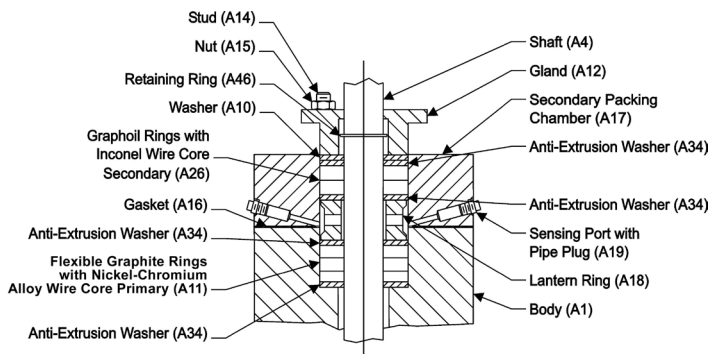

Flexible Carbon Graphite, Dual Seal, Live Loaded, High Cycle Packing (G2DL)

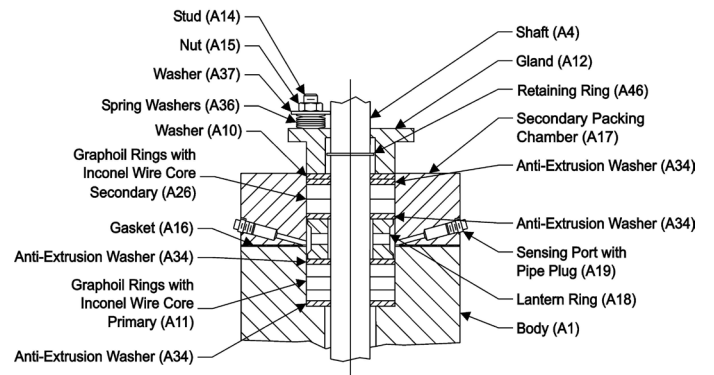

Materials of Construction

Item	Description	Material
A1	Body	Carbon Steel, ASTM A216, Grade WCB
		316 Stainless Steel, ASTM A351, Grade CF8M
		317 Stainless Steel, ASTM A351, Grade CG-3M except with .03% max carbon
A2	Bearing	PTFE Fabric with 317 Stainless Steel Backing, to 500°F (260°C)
		316 Stainless Steel, Diffusion Hardened, to 700°F (371°C)
		Nickel Stainless Steel ASTM A494, Grade CY5SnBiM, to 700°F (371°C)
		316 Stainless Steel Nickel Coated, Heat Treated, to 700°F (371°C)
		316 Stainless Steel, Diffusion Hardened, to 700°F (371°C)
		PTFE Fabric with Hastelloy C Backing, to 500°F (260°C)
A3	Disc	316 Stainless Steel, ASTM A351, Grade CF8M
		316 Stainless Steel, ASTM A351, Grade CF8M, Nickel Overlay, Heated Treated to RC70
		317 Stainless Steel, ASTM A351, Grade CG-3M except with .03% max carbon
A4	Shaft	2205 Duplex Stainless Steel, ASTM A276 Type 2205
		17-4 PH Stainless Steel, ASTM A 564, Type 630, Cond H1150 per NACE MR-01-75
		316 Stainless Steel, ASTM A479, Type 316
A5	Pin	Nitrogen-Strengthened Austenitic Alloy ASTM A479, Type XM-19, Condition A, to NACE MR0175/ISO 15156
		316 Stainless Steel, ASTM A276, Type 316, Flash Chrome Plate
A9	Pipe Plug	Carbon Steel, ASTM A216, Grade WCB, Galvanized
		316 Stainless Steel, ASTM A351, Grade CF8M
		317 Stainless Steel, ASTM A240, Type 317
A10	Packing Washer	316 Stainless Steel, ASTM A240, Type 316
		316 Stainless Steel, ASTM A276, Type 316, Condition A
		316 Stainless Steel, ASTM A511, Type 316
		317 Stainless Steel, A167, Type 317
A11	Packing	PTFE, V-Flex
		Carbon Graphite
A12	Packing Gland	317 Stainless Steel, ASTM A351, Type 317
		316 Stainless Steel, ASTM A511, Grade MT316
A14	Stud	316 Stainless Steel
A15	Gland Nut	316 Stainless Steel
A16	Gasket	Carbon Graphite/Stainless Steel
A19	Pipe Plug	316 Stainless Steel
A20	Seat Retainer	Carbon Steel, ASTM A516, Grade 70 or ASTM A216, Grade WCB
		316 Stainless Steel, ASTM A240, Type 316 or ASTM A351, Grade CF8M
		317 Stainless Steel, ASTM A240, Type 317
A21	Resilient Seat	PTFE, White Virgin
		RTFE, 10% Carbon Graphite Filled PTFE
A22	Seat Control Ring	Titanium, ASTM B265, Grade 3
		Nickel-Chromium Alloy
A23	Screw	316 Stainless Steel
		317 Stainless Steel
A24	Set Screw	316 Stainless Steel
		317 Stainless Steel, ASTM A167, Type 317
A27	Gasket	Carbon Graphite, Commercial Grade GTB
A28	Metal Seat Ring	316 Stainless Steel, ASTM A240, Type 316, Condition A
A30	Seal	PTFE
		Carbon Graphite, Commercial Grade GTB
A31	Cover	Carbon Steel, ASTM A516, Grade 70
		316 Stainless Steel, ASTM A240, Type 316, Condition A
A32	Lock Washer	410 Stainless Steel
		316 Stainless Steel
A33	Screw	Stainless Steel, ASTM A193, Grade B8M, Class 1 or 2
A34	Anti-Extrusion Washer	PTFE/317 Stainless Steel (See page 7)
A37	Washer	Steel, Zinc Plated (See page 7)
A42	Lock Washer	410 Stainless Steel
		316 Stainless Steel
A46	Retaining Ring	303 Series Stainless Steel

Valve Selection

Applicable Standards

DeZURIK BHP High Performance Butterfly Valves are designed and/or tested to meet the following standards:	
ASME B16.1	Cast Iron Pipe Flanges and Flanged Fittings. Class 150 valves mate with pipeline flanges conforming to the Class 125 requirements and Class 300 valves are designed to mate with Class 250 pipe flanges.
ASME B16.20	Metallic Gaskets for Pipe Flanges Ring-Joint, Spiral-Wound, and Jacketed. End connections compatible (within the limits of API 609) with spiral-wound gaskets in accordance with API 601 gaskets. Optional undrilled seat retainer (UR) construction available to provide full seal area contact with API 601 gaskets.
ASME B16.34	Valves-Threaded and Welded End. All BHP Butterfly Valves comply with requirements of this standard.
ASME B16.47	Pipe Flanges and Flanged Fittings. Class 150, Series A, Table I-29; Class 300, Series A, Table I-30. Sizes 28" (700mm) and larger are designed to mate with pipeline flanges conforming to the Series A requirements, Large Diameter Steel Flanges.
ASME B16.5	Pipe Flanges and Flanged Fittings. 2-24" (80-300mm) valves are designed to mate with Class 150 or 300 flanges.
ANSI/FCI 70-2	Control Valve Seat Leakage. Metal-seated valves conform to the Class IV leak rate requirements. All valves are tested to Class IV. If Class V is required, it must be specified as an option to allow for test differences. PTFE and RTFE seat options meet or exceed Class VI requirements.
API 598	Seat/Shell Test. Resilient and Dual Seated Valves meet the leak rate requirements of this standard.
API 607	Fire Test for Soft Seated, Quarter-Turn Valves, 6th Edition. Valves with Fyre-Block (FB) option conform to this requirement.
API 609	Face-to-face dimensions for 3-24" valves conform to Category B Class 150 and Class 300 requirements (Sizes 2", 2.5" and 5" are not named in this standard). Class 150 sizes 28" and larger conform to the requirements of Category A.
AWWA C207	Class 150, Class D (175-150 psi), Table 3 and Class E (275 psi) Table 4.
BS 4504	Conforms to flange bolt guide and pressure ratings.
BS 5146	Inspection and Test of Steel Valves for the Petroleum, Petrochemical and Allied Industries. Dual Seated valves with Fyre-Block (FB) option meet with fire portion of standard.
DIN 2632	Conforms to flange bolt guides and pressure 2635 ratings.
DIN 3230	Leak Rate 1 Requirement. Resilient and Dual Seated Valves meet the leak rate requirements of this standard.
EN 29001	DeZURIK manufacturing processes comply with this quality standard.
ISA D79.01	Level 2 Leak Rates Cryogenic Tests ISA A75.02 Standard Control Valve Capacity Test Procedure.
ISO 5208	Conforms to pressure testing requirements of this standard.
ISO 5211	Conforms to flange bolt guide and pressure ratings.
ISO 5752	All valves designed to comply with face-to-face dimensions.
ISO 7005	Conforms to flange bolt guide and pressure ratings.
ISO 9001	DeZURIK manufacturing processes certified to this quality standard.
JIS B2212	Conforms to flange bolt guide and pressure ratings.
MSS SP-25	Standard Marking System for Valves, Fittings, Flanges, and Unions. All valves comply with requirements of this standard.
MSS SP-44	Steel Pipeline Flanges, Class 150, Annex C, Table C3; Class 300, 740 psi, Annex C, Table C4.
MSS SP-61	Pressure Testing of Steel Valves.
MSS SP-68	High Pressure Offset Seat Butterfly Valves. All valves comply with the requirements of this standard.
NACE MR0175	Sulfide Stress Cracking Resistant Metallic Material for Oil Field Equipment. NACE trim is standard on all valves except metal seated. This construction available as an option with metal seated valves.
NSF/ANSI-61	Certified to NSF/ANSI-61 Drinking Water System Components.
NSF/ANSI-372	Certified to NSF/ANSI-372 with requirements for Lead-free as defined by CA, VT, MD, LA state laws and the US Safe Drinking Water Act.
PED Pressure Equipment Directive	Quality System for the design, manufacture, final inspection and testing meet provisions of the directive.

Shut-Off Capabilities

Seat Type	Shutoff Capability
PTFE & RTFE Seated	Bubble-Tight Shutoff with pressure on either side of the disc
Dual Seated	Class VI - DIN 1 Bubble-Tight Shutoff
Metal Seated	Standard, Class IV unidirectional on seat side. With optional C5, Class V unidirectional on seat side.

Pressure Ratings (Ambient Temperature)

Body Material/Class	Pressure Rating
Carbon Steel, Class 150	285 psi (1960 kPa)
Carbon Steel, Class 300	740 psi (5100 kPa)
Stainless Steel, Class 150	275 psi (1890 kPa)
Stainless Steel, Class 300	720 psi (4960 kPa)

Pressure/Temperature Curves

Metal Seat

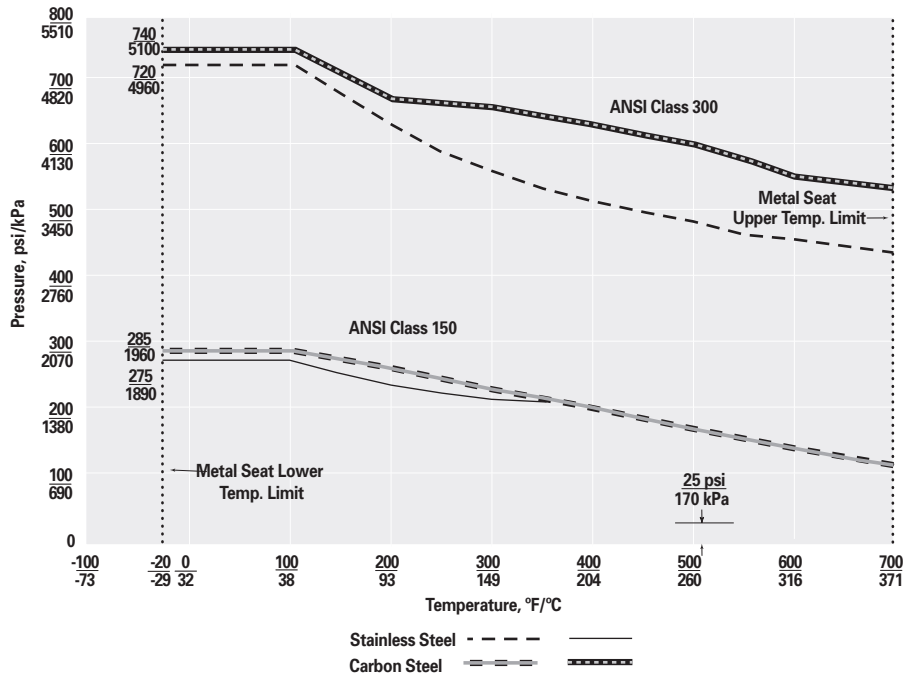

Resilient and Dual Seats

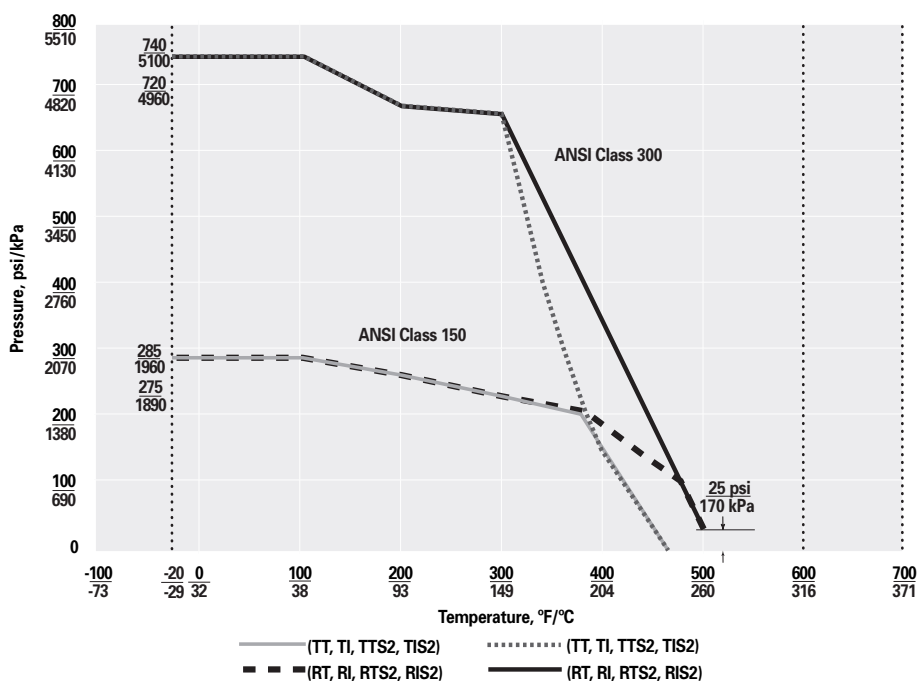

Valve Selection

Flow Parameters

Valve Size	Class 150		Class 300	
	Cv*/Kv* 100% Open	K Factor**	Cv*/Kv* 100% Open	K Factor**
2" 50mm	85 74	2.25	85 74	1.74
2.5" 65mm	180 156	1.02	160 138	1.01
3" 80mm	275 238	1.04	260 225	0.93
4" 100mm	520 450	0.87	475 411	0.85
5" 125mm	860 744	0.78	770 666	0.81
6" 150mm	1360 1176	0.65	1130 977	0.77
8" 200mm	2260 1955	0.71	2110 1825	0.68
10" 250mm	3550 3071	0.71	3350 2898	0.66
12" 300mm	5000 4325	0.72	4800 4152	0.65
14" 350mm	6800 5882	0.57	6390 5527	0.53
16" 400mm	9000 7785	0.56	8460 7318	0.52
18" 450mm	11800 10207	0.52	11100 13500	0.49
20" 500mm	14400 12456	0.54	13500 11678	0.51
24" 600mm	20000 17300	0.58	17700 15311	0.61
28" 700mm	27000 23355	0.67	Contact DeZURIK	
30" 750mm	33300 28805	0.53	26300 22750	0.74
36" 900mm	56500 48873	0.40	47000 40655	0.51
42" 1050mm	67000 57955	0.53	Contact DeZURIK	
48" 1200mm	103000 89095	0.39		
54-60" 1400-1500mm	Contact DeZURIK			

Flow Characteristics

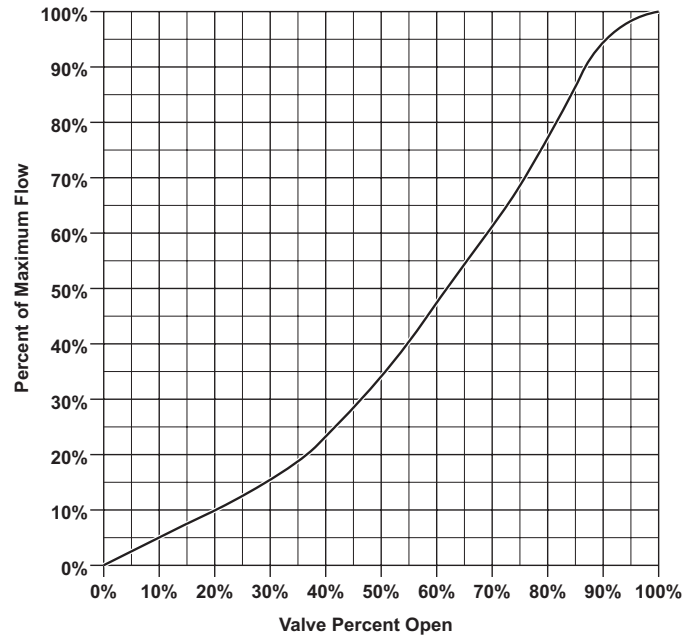

*Cv = Flow in GPM of water at 1 psi pressure drop.

Kv = Flow in m³/hr. of water at 100 kPa pressure drop.

** K = The resistance coefficient of the valve. The constant (K) can be used to determine the equivalent length of pipe.

$L = \frac{K \times D}{f}$ Where
 L = Equivalent length of pipe in feet
 K = Resistance coefficient
 D = Pipe diameter in feet
 f = Friction factor, related to type of pipe

Weights

Basic Valve, Class 150

Valve Size	Wafer Body	Lugged Body
2" 50mm	3 2	7 4
2.5" 65mm	4 2	9 5
3" 80mm	10 5	11 5
4" 100mm	11 5	19 9
5" 125mm	18 9	26 12
6" 150mm	22 10	45 21
8" 200mm	36 17	46 21
10" 250mm	61 28	67 31
12" 300mm	100 46	145 66
14" 350mm	142 65	188 86
16" 400mm	192 88	243 111
18" 450mm	314 143	363 165
20" 500mm	411 187	335 152
24" 600mm	665 302	800 363
28" 700mm	Contact DeZURIK	
30" 750mm	975 443	1175 534
36" 900mm	1560 708	1900 863
42" 1050mm	Contact DeZURIK	4507 2045
48" 1200mm	4015 1822	4545 2063
54-60" 1400-1500mm	Contact DeZURIK	

Basic Valve, Class 300

Valve Size	Wafer Body	Lugged Body
2" 50mm	4 2	11 5
2.5" 65mm	6 3	18 9
3" 80mm	8 4	21 10
4" 100mm	14 7	35 16
5" 125mm	25 12	49 23
6" 150mm	28 13	64 30
8" 200mm	49 23	110 50
10" 250mm	79 36	175 80
12" 300mm	124 57	230 105
14" 350mm	182 83	232 106
16" 400mm	246 112	312 142
18" 450mm	402 183	465 211
20" 500mm	525 239	613 279
24" 600mm	736 334	1025 466
30" 750mm	Contact DeZURIK	3000 1362
36" 900mm		4350 1974

Pounds
Kilograms

Note: Weights are approximate and do not include crating.

Ordering

To order, simply complete the valve order code from information shown. An ordering example is shown for your reference.

Valve Style	
Give valve style code as follows:	
BHP	= High Performance Butterfly Valve

Valve Size			
Give valve size code as follows:			
2	= 2" (50mm)	18	= 18" (450mm)
2.5	= 2.5" (65mm)	20	= 20" (500mm)
3	= 3" (80mm)	24	= 24" (600mm)
4	= 4" (100mm)	28	= 28" (700mm)
5	= 5" (125mm)	30	= 30" (750mm)
6	= 6" (150mm)	36	= 36" (900mm)
8	= 8" (200mm)	42	= 42" (1050mm)
10	= 10" (250mm)	48	= 48" (1200mm)
12	= 12" (300mm)	54	= 54" (1400mm)
14	= 14" (350mm)	60	= 60" (1500mm)
16	= 16" (400mm)		

End Connection	
Give end connection code as follows:	
Class 150 Wafer	
W1	= ASME
W110	= DIN 10 or BS4504/10 Drilling
W116	= DIN 16 or BS4504/16 Drilling
W1D	= B.S. Table D Drilling
W1E	= B.S. Table E Drilling
W1J1	= JIS 10 Drilling
Class 150 Lugged	
L1	= ASME
L110	= DIN 10 or BS4504/10 Drilling
L116	= DIN 16 or BS4504/16 Drilling
L1D	= B.S. Table D Drilling
L1E	= B.S. Table E Drilling
L1J1	= JIS 10 Drilling
Class 300 Wafer	
W2	= ASME
W225	= DIN 25 or BS4504/25 Drilling
W240	= DIN 40 or BS4504/40 Drilling
W2F	= B.S. Table F Drilling
W2H	= B.S. Table H Drilling
W2J	= B.S. Table J Drilling
W2J2	= JIS 20 Drilling
Class 300 Lugged	
L2	= ASME
L225	= DIN 25 or BS4504/25 Drilling
L240	= DIN 40 or BS4504/40 Drilling
L2F	= B.S. Table F Drilling
L2H	= B.S. Table H Drilling
L2J	= B.S. Table J Drilling
L2J2	= JIS 20 Drilling

Body Material	
Give body material code as follows:	
CS	= Carbon Steel
S2	= 316 Stainless Steel
S3	= 317 Stainless Steel (3-12" except 5" Class 150 Lugged only)
On Application	
AA	= Alloy 20
HC	= Hastelloy C
ML	= Monel
T3	= Titanium Grade 3

Packing Material	
Give packing material code as follows:	
TC	= PTFE V-Flex, to 500°F (260°C)
G1	= Carbon Graphite to 700°F (371°C)
Special Packing	
G2	= Flexible Graphite to 1000°F (538°C)
TCD	= PTFE V-Flex, Dual Seal, Low Cycle to 500°F (260°C)
TCDL	= PTFE V-Flex, Dual Seal, Live Loaded, Low Cycle to 500°F (260°C)
TCL	= PTFE V-Flex, Live Loaded, Low Cycle to 500°F (260°C)
G2D	= Flexible Graphite, Dual Seal, High Cycle to 1000°F (538°C)
G2L	= Flexible Graphite, Live Loaded, High Cycle to 1000°F (538°C)
G2DL	= Flexible Graphite, Dual Seal, Live Loaded, High Cycle to 1000°F (538°C)

Trim Combination	
Disc Material	
Give disc material code as follows:	
S2	= 316 Stainless Steel
S2NH	= 316 Stainless Steel Nickel Plated Heat Treated (must use 17-4 PH Shaft material)
S3	= 317 Stainless Steel (used with S10 Shaft, FT bearings and TT, TI, RT or RI seat)
On Application	
AA	= Alloy 20
CSN	= Carbon Steel Nickel Coated (24" and larger only)
CSNH	= Carbon Steel Nickel Coated Heat Treated (24" and larger only) (must use 17-4 PH Shaft material)
HC	= Hastelloy C
ML	= Monel
TN3	= Titanium Grade 3 (anodized)

Shaft Material (2-20")	
Give shaft material code as follows:	
S10	= 2205 Duplex
S10B	= 2205 Duplex (used only with L1 or W1 end connection, CS or S2 body material & TT, TI, RT or RI seat)
S5A	= 17-4 PH Stainless Steel
S5B	= 17-4 PH Stainless Steel (used only with L1 or W1 End Connection CS or S2 Body Material & TT/TI/RT/TI Seats)

Shaft Material (24-60")	
S2	= 316 Stainless Steel
S5	= 17-4 PH Stainless Steel
On Application (all sizes)	
AA	= Alloy 20
HC	= Hastelloy C
ML	= Monel
T5C	= Titanium Grade 5 (ceramic coated)

Bearing Material	
Give bearing material code as follows:	
FT	= PTFE Fabric with 317 Stainless Steel Backing, to 500°F (260°C)
NS	= 316 Stainless Steel, Diffusion Hardened, to 700°F (371°C) Sizes 2-20"
NS	= Nickel Stainless Steel ASTM A494, Grade CYSnBiM, to 700°F (371°C) Sizes 24" and Larger
NS	= 316 Stainless Steel Nickel Coated, Heat Treated, to 700°F (371°C) Used with NT option
S2	= 316 Stainless Steel, Diffusion Hardened, to 700°F (371°C) 24" and Larger with NSF option
On Application	
FH	= PTFE Fabric with Hastelloy C Backing, to 500°F (260°C)

Seat Seal/Seat Control Ring Material	
Give seat material code as follows:	
Standard Seats	
TT	= PTFE/Titanium to 450°F (232°C)
TTS2	= PTFE/Titanium and 316 Stainless Steel to 450°F (232°C)
S2	= 316 Stainless Steel, to 700°F (371°C), must use Graphite packing and NS bearings or to 450°F (232°C), recommended with TC packing and FT bearing. Not available on 5" valve.
Special Seats	
TI	= PTFE/Nickel-Chromium Alloy, to 450°F (232°C). For oxygen service.
TIS2	= PTFE/Nickel-Chromium Alloy and 316 Stainless Steel, to 450°F (230°C). For oxygen service.
RT	= Reinforced PTFE/Titanium, to 500°F (260°C)
RTS2	= Reinforced PTFE/Titanium and 316 Stainless Steel, to 500°F (260°C)
RI	= Reinforced PTFE/Nickel-Chromium Alloy, to 500°F (260°C)
RIS2	= Reinforced PTFE/Nickel-Chromium Alloy and 316 Stainless Steel, to 500°F (260°C)
Note: Any seat seal/seat control ring combination with S2 seat is not available in 5" (125mm) or 54" (1400mm) sizes.	

Ordering (Continued)

Options

Give options code as follows:

- NSF = Certified to NSF/ASME Standard 61 Drinking Water System Components
- FB = Conforms to ASME/API 607 Sixth Edition Fire Test for Soft-Seated Quarter Turn Valves. API 607 Sixth Edition does not cover the testing requirements for valve actuators other than manually operated gear boxes or levers.
- BAA = Buy American Act
- CRT = Certified Material Physical & Chemical Test Report
- CMC = Certificate of Material Conformance
- DTR = DeZURIK Standard Certified Production Hydrostatic Shell and Seat Test Report
- UR = Undrilled Seat Retainer - Available on 2-10" lugged valves only. Not rated for dead end service.
- C5 = Class 5 Seat Test for (S2) metal seated valves per ASME B16.104/FCI70.2
- 15 = 150 psi Disc - 36" & Larger (Not available with Dual Seat, Fyre Block or Metal Seats)
- NT = ANSI/NACE MR0175/ISO 15156, Petroleum and natural gas industries, Materials for use in H2S-containing environments in oil and gas production. Specify (NT) NACE Trim when NS bearings are ordered. All other combinations are NACE Certified as standard.
- API = Conforms to API-609 Butterfly Valves: Double Flanged, Lug- and Wafer-Type and API-598 Valve Inspection and Testing. Conformance to these API standards do not apply to valves with the (S2) metal seat because of allowable seat leak rate or valve sizes 2", 2.5" or 5".

On Application

- = Pressure Equipment Directive (CE Mark)

Ordering Example

BHP,6,W1,CS,TC,S2-S10-FT-TT*Actuator

NOTE: For High Temperature Service, the limiting factor in valve selection is the lowest temperature rating of the packing, bearing or seat seal material.

Manual Actuators

10-Position Levers

A 10-position dial provides positive latching in open, closed and eight intermediate positions. A pointer indicates position of disc plus a notch in the handle allows use of a padlock to prevent unauthorized valve operation.

Mounting

Lever actuators can be mounted at standard and 180° clockwise from standard. Specify mounting positions other than standard below the valve and actuator identification.

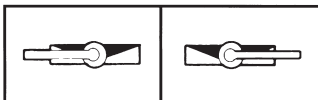

Standard Mounting

180° Clockwise

Ordering

To order, add lever code LT to basic valve identification. Lever actuators available on 2–8" (50–200mm) Class 150 and Class 300 valve sizes only.

Handwheel actuators are recommended for valve sizes over 6" (150mm) and where water hammer may occur due to a sudden valve closure. Maximum pipeline velocity for lever operated valve is 20 feet (6 meters) per second.

Lever Actuator Sizing

Class 150

Valve Size	Order Code	Maximum Shutoff Pressure Differential psi/kPa		
		TT/TI RT/RI	TTS2/TIS2 RTS2/RIS2	S2/TTS2 & FB RTS2 & FB
2-6" 50-150mm	LT	285 1960	285 1960	285 1960
8" 200mm	LT	285 1960	285 1960	50 340

Note: Stainless Steel valves are rated to 275 psi (1890 kPa).

Class 300

Valve Size	Order Code	Maximum Shutoff Pressure Differential psi/kPa		
		TT/TI RT/RI	TTS2/TIS2 RTS2/RIS2	S2/TTS2 & FB RTS2 & FB
2 & 4" 50 & 100mm	LT	740 5100	740 5100	740 5100
6" 150mm	LT	740 5100	650 4480	300 2070
8" 200mm	LT	740 5100	450 3100	50 340

Note: Stainless Steel valves are rated to 720 psi (4960 kPa).

Ordering Example:

BHP,3,L1,S2,TC,S2-S10B-FT-TT*LT

Memory Stop

An adjustable memory stop is available which allows return of the valve to preset open position after shutoff. Order the memory stop as part of a complete valve, by adding "ST" after the actuator code.

Ordering Example:

BHP,3,L1,S2,TC,S2-S10B-FT-TT*LT,ST

Actuators

MG Manual Gear Actuators

Manual gear actuator housings are constructed of high strength metal and feature sintered bronze bearings on each end of the input shaft for durability and performance. The high strength gear provides strength for robust applications and a long service life without maintenance. All manual gear actuators feature external position indication and are available with safety lockout devices. Actuators for buried service are available as an option.

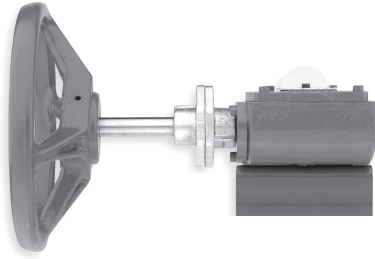

G-Series Manual and Cylinder Actuators

Rotary manual actuators feature a cast iron housing with bearings on each end of the input shaft for durability and performance. The ductile iron gear provides strength for robust applications and a long service life without maintenance. Rotary manual actuators are available with handwheel, chainwheel, or a 2" (50mm) square nut input option. Actuators feature external position indication and are available with safety lockout devices.

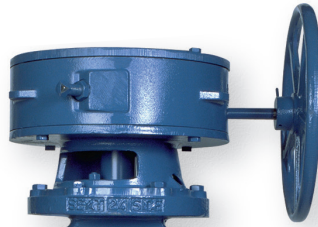

Compak Cylinder Actuators

Compak actuators are a versatile rack-and-pinion design and are available as double-acting or spring-return units. The compact, modular design allows the actuator to be mounted for a low profile assembly. Compak actuators are matched to each valve's torque requirements to ensure that the most economical valve and actuator package is specified.



PowerRac® Cylinder Actuators

PowerRac double-acting and spring-return actuators feature a proven rack-and-pinion design. PowerRac® provides high torque output throughout the full stroke for accurate control.

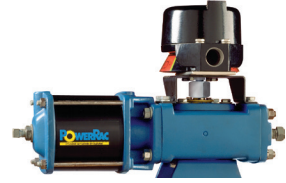

Spring-Diaphragm Actuators

DeZURIK spring-diaphragm actuators feature all steel, cast iron and stainless steel construction with no aluminum parts to corrode in caustic environments. The output shaft is supported at the top and bottom with bronze bearings that absorb side thrust and ensure smooth, efficient throttling control. Diaphragm actuators provide on-off or modulating control with either spring-to-spring or spring-to-close operation. All diaphragm actuators feature external position indication and are available with safety lockout devices.

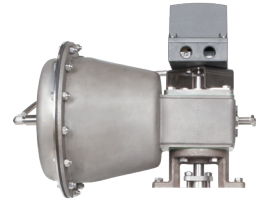

Dimensions

Basic Valve

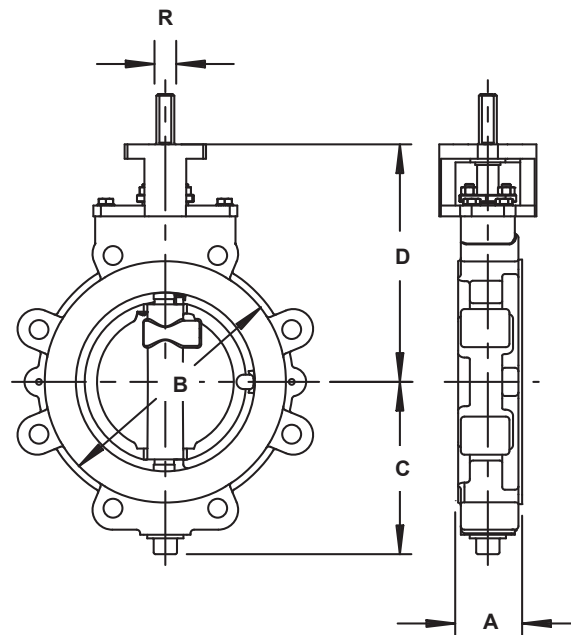

Valve Size	Dimensions											
	A		B				C		D		R (Dia.)	
	Class 150	Class 300	Class 150		Class 300		Class 150	Class 300	Class 150	Class 300	Class 150	Class 300
			Wafer	Lugged	Wafer	Lugged						
2" 50mm	1.75 44	1.75 44	4.31 110	6.06 154	4.31 110	6.44 164	3.31 84	3.50 89	5.50 140	5.50 140	0.371 9	0.371 9
2.5" 65mm	1.88 48	1.88 48	5.00 127	7.00 178	5.00 127	7.44 189	3.44 87	4.00 102	5.75 146	6.00 152	0.371 9	0.434 11
3" 80mm	1.88 48	1.88 48	5.66 144	7.62 194	5.66 144	8.19 208	3.97 101	4.38 102	6.00 152	6.38 162	0.434 11	0.496 13
4" 100mm	2.12 54	2.12 54	6.78 172	9.00 229	6.78 172	9.75 248	4.75 121	5.06 129	6.75 171	7.75 197	0.496 13	0.621 16
5" 125mm	2.31 59	2.31 59	7.69 195	10.00 254	7.75 197	10.94 278	5.50 140	5.94 151	7.75 197	8.25 210	0.621 16	0.746 19
6" 150mm	2.31 59	2.44 62	8.88 226	11.00 279	9.00 229	12.44 316	6.50 165	7.16 182	8.25 210	9.00 229	0.746 19	0.995 25
8" 200mm	2.50 64	2.88 73	11.00 279	13.50 343	11.12 282	14.88 378	7.59 193	8.47 215	9.50 241	10.75 273	0.995 25	1.245 32
10" 250mm	2.93 74	3.36 85	13.75 349	16.12 409	13.25 337	17.50 445	8.78 223	10.06 256	11.19 284	12.62 321	1.245 32	1.495 38
12" 300mm	3.28 83	3.72 95	15.50 394	19.12 486	15.50 394	20.38 518	10.19 259	11.38 289	12.75 324	13.75 349	1.495 38	1.745 44
14" 350mm	3.61 92	4.64 118	16.50 419	21.00 533	16.62 422	22.25 565	11.81 300	12.84 326	14.00 356	16.88 429	1.495 38	1.870 48
16" 400mm	3.99 101	5.26 134	18.75 476	23.50 597	18.69 475	24.50 622	12.94 329	13.81 351	15.75 400	14.25 362	1.620 41	1.995 51
18" 450mm	4.43 113	5.89 150	21.25 540	25.00 635	21.38 543	27.00 686	14.31 329	16.00 406	18.62 473	15.50 394	1.870 48	2.245 57
20" 500mm	4.92 125	6.26 159	23.25 591	27.75 705	23.50 597	29.25 743	15.81 402	16.81 427	20.56 522	16.75 425	2.245 57	2.449 63
24" 600mm	6.12 155	7.22 183	27.25 692	32.00 813	27.50 699	34.50 876	17.31 440	20.06 510	17.75 451	19.69 500	2.499 63	3.624 92
28" 700mm	6.50 165	—	—	36.50 927	—	—	19.88 505	—	20.00 508	—	2.998 76	—
30" 750mm	6.50 165	9.88 251	33.75 857	38.75 984	34.12 867	43.00 1092	21.06 535	25.84 656	21.12 536	25.00 635	2.999 76	4.499 114
36" 900mm	7.88 83	10.88 276	40.25 1022	46.00 1168	40.88 1038	50.00 1270	25.38 645	28.75 730	25.00 635	28.50 724	3.624 92	5.000 127
42" 1050mm	9.88 251	—	53.00 1346	47.25 1200	—	—	28.94 735	—	30.00 762	—	4.499 114	—
48" 1200mm	10.88 276	—	59.50 1511	53.81 1367	—	—	32.50 826	—	31.68 805	—	5.000 127	—
54-60" 1400-1500mm	Contact DeZURIK											

Inches
Millimeters

NOTE: All dimensions are subject to change without notice. For piping layouts, request certified drawings.

Dimensions

Lever

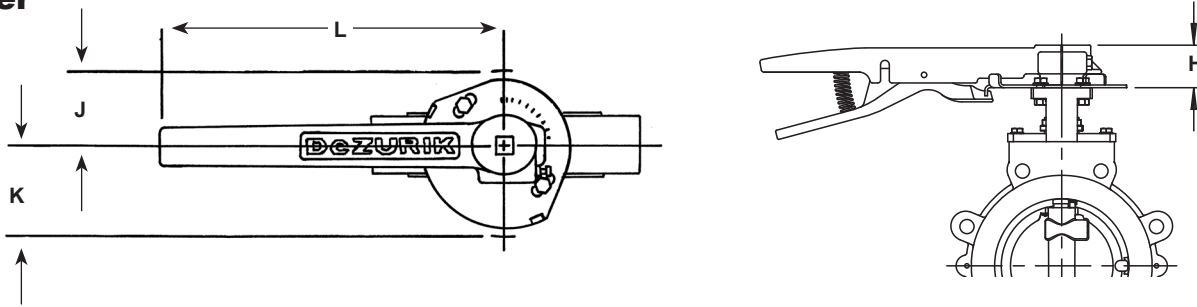

Valve Size	Dimensions										
	H	J		K		L					
		Class 150	Class 300	Class 150	Class 300	Resilient Seats (RT, RI, TT & TI)		Dual Seat (TTS2, TIS2, RTS2 & RIS2)		Metal Seat (S2)	
						Class 150	Class 300	Class 150	Class 300	Class 150	Class 300
2" 50mm	2.00 51	2.00 51	2.00 51	2.44 62	2.44 62	10.00 254	10.00 254	10.00 254	10.00 254	10.00 254	10.00 254
2.5" 65mm	2.00 51	2.00 51	2.00 51	2.44 62	2.44 62	10.00 254	10.00 254	10.00 254	10.00 254	10.00 254	10.00 254
3" 80mm	2.00 51	2.00 51	2.00 51	2.44 62	2.44 62	10.00 254	10.00 254	10.00 254	10.00 254	10.00 254	10.00 254
4" 100mm	2.00 51	2.00 51	3.00 72	2.44 62	3.56 90	10.00 254	10.00 254	10.00 254	10.00 254	10.00 254	10.00 254
5" 125mm	2.00 51	2.00 51	3.00 72	2.44 62	3.56 90	10.00 254	14.00 356	—	—	—	—
6" 150mm	2.25 57	3.00 72	3.00 72	3.56 90	3.56 90	14.00 356	22.00 559	14.00 356	22.00 559	22.00 559	22.00 559
8" 200mm	2.25 57	3.00 72	3.00 72	3.56 90	3.56 90	22.00 559	22.00 559	22.00 559	22.00 559	22.00 559	22.00 559

Inches
Millimeters

2" (50mm) Square Nut, G-Series Actuator

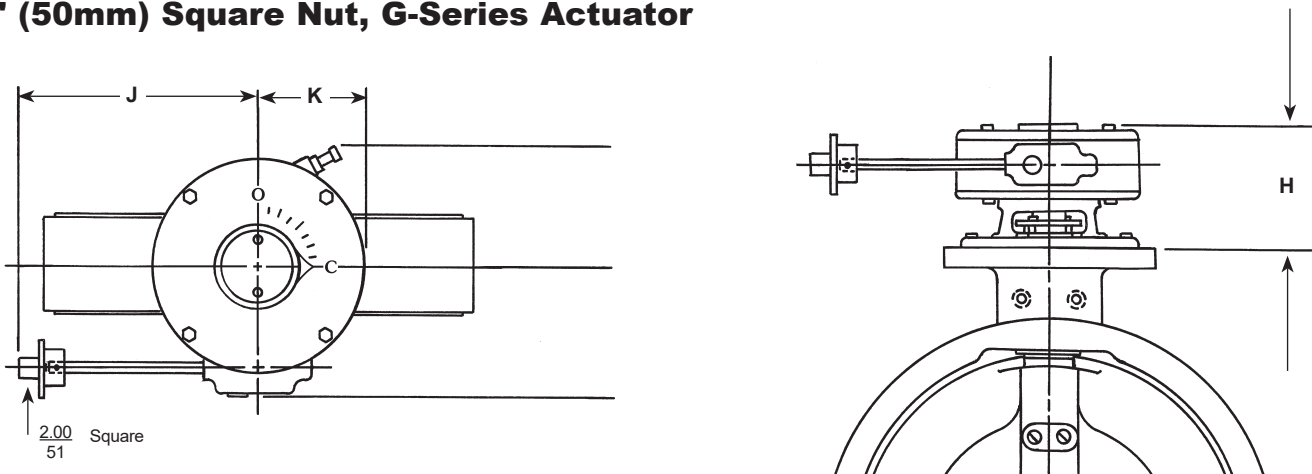

Actuator Code	Dimensions				
	H	J	K	L	M
GS-12-N	10.37 263	16.38 416	7.88 200	9.25 235	9.50 241

Note: H dimension on 14" (350mm) valve with GS-12-N is 11.25
286

Inches
Millimeters

Note: All dimensions are subject to change without notice. For piping layouts, request certified drawings.

Dimensions

Handwheel, G-Series Actuator

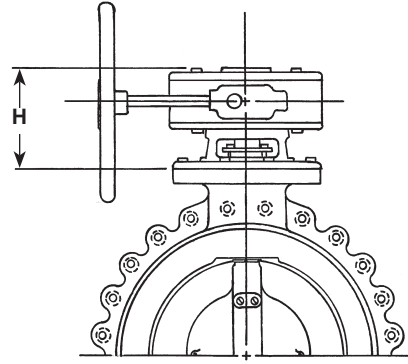
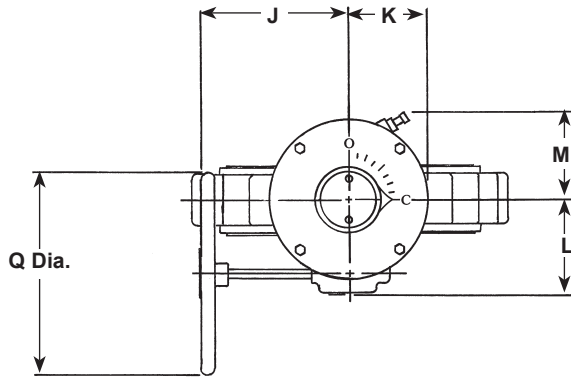

Actuator Code	Dimensions					
	H	J	K	L	M	Q
GS-12-HD16	10.37	13.50	7.88	9.25	9.50	16.00
	263	343	200	235	241	406
GS-12-HD24	10.37	17.50	7.88	9.25	9.50	24.00
	263	445	200	235	241	610
GS-12-HD30	10.37	17.50	7.88	9.25	9.50	30.00
	263	445	200	235	241	762

Note: H dimension on 14" (350mm) valve with GS-12-HD24 is $\frac{11.25}{286}$

Chainwheel, G-Series Actuator

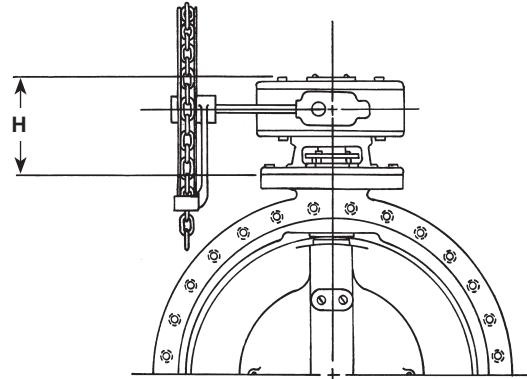
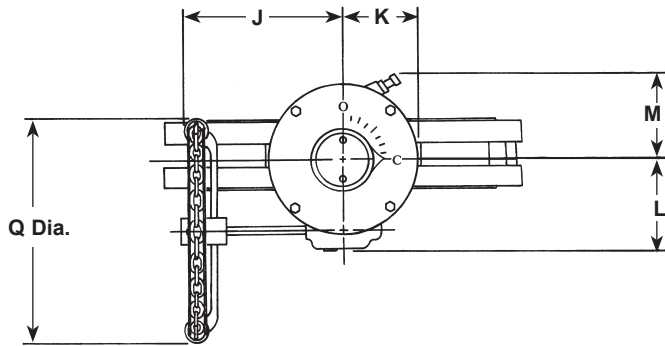

Actuator Code	Dimensions					
	H	J	K	L	M	Q
GS-12-CW20	10.37	13.50	7.88	9.25	9.50	16.00
	263	343	200	235	241	406
GS-12-CW30	10.37	17.50	7.88	9.25	9.50	24.00
	263	445	200	235	241	610

Note: H dimension on 14" (350mm) valve with GS-12-CW20 is $\frac{11.25}{286}$

Inches
Millimeters

Sales and Service

For information about our worldwide locations, approvals, certifications and local representative:

Web Site: DeZURIK.com **E-Mail:** info@DeZURIK.com



250 Riverside Ave. N. Sartell, Minnesota 56377 • Phone: 320-259-2000 • Fax: 320-259-2227

DeZURIK, Inc. reserves the right to incorporate our latest design and material changes without notice or obligation. Design features, materials of construction and dimensional data, as described in this bulletin, are provided for your information only and should not be relied upon unless confirmed in writing by DeZURIK, Inc. Certified drawings are available upon request.

AMS-KSEIndonesia Corp



PT. APINDO MITRA SELARAS

Serang Office :

Komp. Lebak Indah Griya Asri
Blok D4-D5 No.17 & No.05
Waringin Kuring - Kramatwatu
Serang, Banten
42161

Cilegon Office :

Jl. Raya Pondok Cilegon Indah
Ruko Cilegon City Square Blok I No.7
Kedaleman - Cibeber
Cilegon, Banten
42422

aris@kseindonesia.com - sales@kseindonesia.com - cso@kseindonesia.com

www.kseindonesia.com